

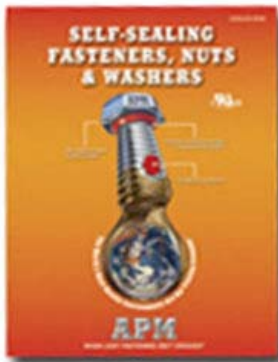

Edition 211, March 2014 | [Self-Sealing Fasteners](#) | [Sealing Boots Division](#)

[Request Catalogs](#)



[Request Boot Samples](#)



[Request Fasteners](#)



ASK APM

Why does the APM SEELNUT® use a sophisticated, molded-in elastomeric seal instead of a simple, pressed-in O-Ring?



After patenting the original line of self-sealing fasteners ([screws, bolts and rivets](#)) in 1949, which features an embedded O-Ring in a proprietary, asymmetrical

groove located in the underside of the fastener's head, our designers looked at designing a sealing nut using a similar approach, but instead determined, because of a totally different dynamic, that the idea of installing an O-Ring on a sealing-nut would NOT be the optimal solution. In order to install an O-

[Watch All Videos](#)



[Download Literature](#)



Ring onto a sealing nut, the first/second thread of the nut must be removed, weakening the gripping power and clamp load of a torqued nut. Simply installing a conventional O-Ring into the newly made groove does not compensate for the lost holding strength. In addition, there is a critical secondary problem of O-Ring damage due to the cutting effect from the mating part's sharp thread edges. As the O-Ring is degraded each time it is tightened, the uncertainty of sealing increases. Our engineers developed a superior design, employing a molded-in elastomeric seal (typically silicone rubber) with integral sealing rib and threads that distort slightly when tightened, providing 100% gripping and sealing. There is also no cutting or other damage to the sealing material, maximizing reusability. Given this, we find it strange that any competitor would continue to market a sealing nut that utilizes an O-Ring. APM Hexseal's superior sealing design allows the SEELNUT® to achieve a 6,000psi internal/vacuum rating - a feat that could not

be accomplished with a simple pressed O-Ring.

[UL Recognized,](#)

[APM Hexseal](#)

[SEELNUTS®](#)

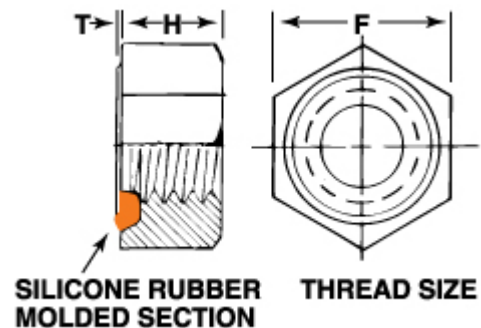

are reusable and fully adjustable; they resist vibration and are available with the additional thread locking options of a nylon pellet or nylon patch. Nuts are available in plated steel, stainless steel and a wide range of thread sizes (Imperial and Metric) and types (hex, jam, acorn, etc.).



APM NEWS

Stainless-Steel Pushbutton Switch Boot Passed Additional Tough Tests with Flying Colors



The [APM Hexseal armored pushbutton](#) was tested to the tough IP69K standard with a high-powered pressure washer. A competitor was tested and the rubber was cut by the jets, but the stainless steel pushbutton wasn't affected.

The fact that the boot's exterior is constructed of [No.300 stainless steel](#) providing an armor plate thick enough to resist high-pressure wash downs and high temperatures utilized in food, beverage, dairy, pharmaceutical, petrochemical processing industries, and marine, medical, construction, mining and transportation equipment. Designed to meet MIL-DTL-5423 specification rugged conditions, resistant to salt spray, sunlight, ozone weather, fungus, and most acids, detergents and lubricating oils. UL recognized and features an operational life of 100,000 actuations. [View Information.](#)

APM Hexseal Corporation newsletter@apmhxseal.com | <http://www.apmhxseal.com>