

ignion[™]

Your innovation.
Accelerated.

Design guide to cellular IoT antenna integration (with Nordic nRF9160)

DESIGN GUIDE
TRIO mXTEND[™] (NN03-310)
DUO mXTEND[™] (NN03-320)

Design guide to cellular IoT antenna integration (with Nordic nRF9160)

When designing IoT devices with cellular connectivity it is critical to ensure an optimized antenna to pass the cellular certifications. This design guide presents 5 cellular IoT antenna reference designs with Ignion Virtual Antenna® components combined with Nordic Semiconductor cellular wireless modules. The results show how the antenna performance can be affected when you modify the size of your device's PCB, including the influence of different materials (metal, concrete, wood, body) near the device.

Ignion TRIO mXTEND™ and DUO mXTEND™ antenna components showcased in this design guide are used to cover the global cellular IoT bands and GPS. This design guide covers:

- Recommended antenna design steps with examples from simulation to certified device.
- Total efficiency impact by PCB size and materials in proximity.

Nordic Thingy:91 prototyping platform – Example use of Ignion Virtual Antenna® technology

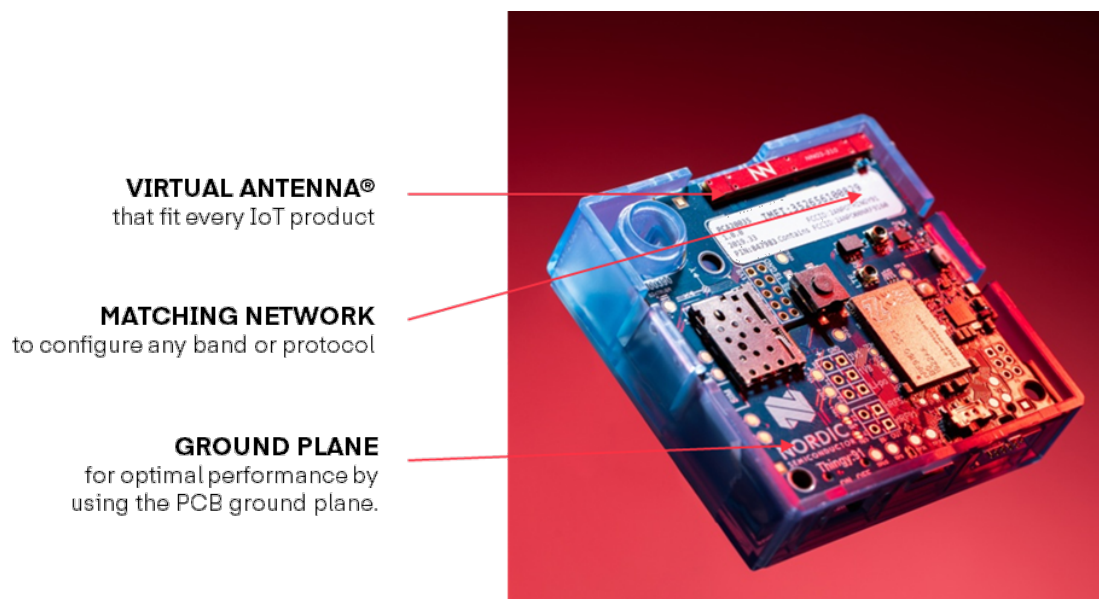

Antenna Intelligence Cloud™ - Nordic
Get your free antenna design and simulation report in less than 24h



Frequency bands showcased in this design guide:

- LTE: 698-960 MHz and 1710-2200 MHz with the TRIO mXTEND™
 - Covered bands: B68, B85, B12, B28, B44, B17, B29, B67, B13, B14, B20, B27, B26, B18, B5, B6, B19, B8, B70, B3, B4, B10, B66, B9, B2, B35, B39, B25, B33, B15, B37, B1, B65, B36, B23, B34.
- GPS L1: 1575 MHz with the DUO mXTEND™

TABLE OF CONTENTS

1. ANTENNA & MODULE COMPONENTS	4
2. VIRTUAL ANTENNA® DESIGN JOURNEY	6
2.1. SHORTENED DESIGN JOURNEY	7
2.2. DESIGN STEPS WITH VIRTUAL ANTENNA® TECHNOLOGY	7
3. STEP BY STEP GUIDE WITH EXAMPLES	9
3.1. SIMULATIONS	10
3.2. PROTOTYPING	16
3.3. LAB MEASUREMENTS	17
3.4. MEETING CERTIFICATION REQUIREMENTS	21
4. PCB SIZE INFLUENCE	23
4.1. 5 REFERENCE BOARD FORM FACTORS	23
4.2. TOTAL EFFICIENCY vs BOARD SIZE	24
4.3. HIGH PERFORMANCE IN SMALL DEVICES	25
5. INFLUENCE BY MATERIALS IN PROXIMITY	30
5.1. WOOD – NO SIGNIFICANT EFFECT	31
5.2. CONCRETE	31
5.3. BODY PHANTOM	32
5.4. METAL	34
6. SUMMARY OF DESIGN STEPS	35
6.1. OVERVIEW OF IGNION SUPPORT SERVICES	36

1. ANTENNA & MODULE COMPONENTS

TRIO mXTEND™
(NN03-310)



Dimensions:

30.0 mm x 3.0 mm x 1.0 mm

Weight: 0.25g

The **TRIO mXTEND™ chip antenna component** (NN03-310) has been specifically designed for providing the highest level of flexibility to operate any required frequency band inside any wireless device.

TRIO mXTEND™ can be used in its **single port or multiport configuration**. Several radios can be allocated inside the same antenna component when used in its multiport configuration. This allows operation in a great variety of communication standards through the same single antenna piece. This modular design **considerably reduces the integration complexity while saving cost, time and space**.

TRIO mXTEND™ chip antenna component not only offers the versatility of being used in a single port or multiport configuration but also offers the flexibility to be **tuned at the frequency regions of interest through just the proper adjustment of the matching network**. This characteristic provides an important benefit since it allows designers to easily adapt the antenna performance to the different device requirements constraints or environmental conditions without the need of changing the antenna component as it will be seen along the document.

DUO mXTEND™
(NN03-320)



Dimensions:

7.0 mm x 3.0 mm x 2.0 mm

Weight: 0.11g

DUO mXTEND™ is a dual-port, chip antenna component designed to embed up to two independent radios in the smallest antenna footprint. Due to its Virtual Antenna® technology, DUO mXTEND™ can support many other wireless technologies making it the ideal antenna part for indoor/outdoor tracking devices. **DUO mXTEND™ has been engineered so it can be mounted in both slot and monopole configurations: Usually, in the slot configuration, no ground clearance around the component is needed.**

Only a minimum clearance underneath the exact footprint of the component is needed to obtain the best radiation efficiency in most cases. Moreover, the component has been designed for dual mounting: either at the center edge of your device or at a corner, making this antenna flexible and easy to adapt to a variety of devices and radio configurations.

nRF9160

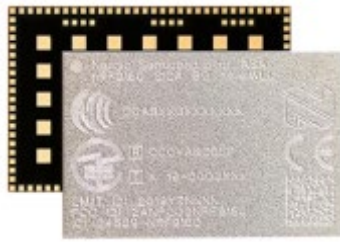

Dimensions:

10 mm x 16 mm x 1.0 mm LGA

nRF9160 is a low power cellular IoT System-in-Package powered by Nordic Semiconductor with integrated LTE-M, NB-IoT and GPS L1, supporting LTE bands from 700 MHz to 2.2 GHz through a single typical 50 Ω antenna pin. It features an output power up to 23 dBm and an RX sensitivity of -108 dBm at LTE-M and -114dBm at NB-IoT (HD-FDD mode).

It includes a 1.8 V MIPI RFFE (RF front-end) digital control interface and MAGPIO control interface for external RF applications **and a LTE modem RF control with external interface**

nRF9160 provides a dedicated 1.8 V digital interfaces for controlling external RF applications, such as antenna tuner devices: MIPI RFFE interface pins: VIO, SCLK, SDATA. MAGPIO interface pins are: MAGPIO0, MAGPIO1, and MAGPIO2.

The LTE modem drives these outputs timing accurately according to LTE protocol timing to set the correct antenna tuner settings per used frequency. User needs to inform the LTE modem through the modem API about the particular RF application e.g. antenna tuner device configuration, so that LTE modem knows how to drive it.

QM13345



Dimensions:

1.1 mm x 1.5 mm x 0.44 mm

The QM13345 is specifically designed for wideband and high-performance tuning applications. With ultra-low RON and low COFF (figure of merit that is used to rate the performance of an RF switch) coupled with selectable OFF ports to eliminate parasitic resonances enables the creation of advanced tuning architectures to maximize Total Radiated Power (TRP) & Total Isotropic Sensitivity (TIS).

- Very Good Performance
 - o Ultra-Low RON: 0.8Ω
 - o Very Low COFF: 145fF
- High RF voltage handling capability: >60Vp
- RFFE 2.1 Control Interface
- Requiring only a single supply – VIO (No VDD)
- Off Ports. ‘OPEN Type’ or ‘GROUND Type’
- 3 Selectable USID using an external pin. ID
- Very Small 1.1mm x 1.5mm. module package
- Suitable for all cellular applications including 5G with broadband performance up to 7.2GHz

2. VIRTUAL ANTENNA® DESIGN JOURNEY

The Virtual Antenna® technology consists of 3 main elements:

- ANTENNA COMPONENT**
that fit every IoT product
- MATCHING NETWORK**
to configure any band or protocol
- GROUND PLANE**
for optimal performance by
using the PCB ground plane.

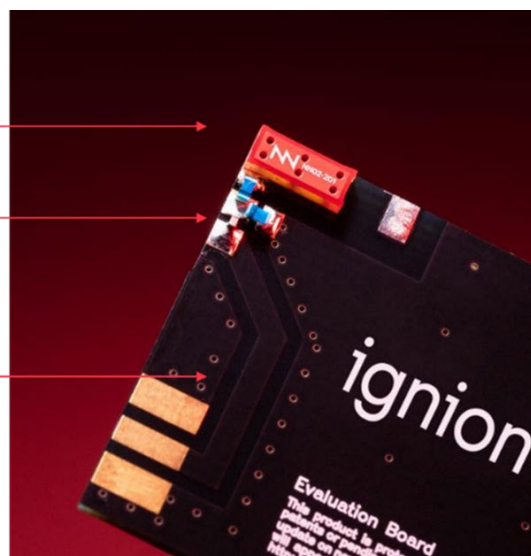

Antenna component: This is a small, wideband and/or multiband antenna component, also called antenna booster. The component is mounted directly on the printed circuit board (PCB) using pick-and-place machinery and usually requires a clearance area around it. Unlike standard surface mount technology (SMT) chips, the component's role is not to resonate at a specific frequency but to maximize the transfer of power from the radio frequency module to the ground plane, and vice versa. This unique capability enables the Virtual Antenna® components to support a frequency range from 698 MHz to 10 000 MHz.

Matching network: The matching network is a series of low-cost standard capacitors and inductors placed between the radio and the antenna component. Environmental factors can cause a shift in the natural resonance of a traditional antenna system leading to suboptimal performance. A matching network is used to retune the antenna impedance, however limited to the antenna components operational bands. However, in a Virtual Antenna® solution, the matching network is defining the frequencies of operation and maximizing the transfer of RF energy from the wireless module to the ground plane. Any Virtual Antenna® configuration can easily be adjusted to any frequency by tuning the matching network and can be done at any stage of the design journey.

Ground plane: Traditional SMT chip antennas use the ground plane to reduce the required length of the antenna to provide the best performance. A Virtual Antenna® component does not resonate like a traditional antenna. Instead, the resonance transmitting the radio waves for communications is achieved using the ground plane. In contrast to traditional bulky SMT chip antennas, the Virtual Antenna® components are the smallest on the market due to resonating purely through the ground plane.

2.1. SHORTENED DESIGN JOURNEY

The main differences between the standard antenna design journey and the Virtual Antenna® design journey are the customizable capabilities of Virtual Antenna® technology allowing IoT designers to easily match the antenna system to the desired communication frequencies. The flexibility advantage of the technology enables the hardware designer to adjust the antenna response in all design stages, making it robust for unforeseen requirement/design changes, thus avoiding continuous redesigns of the board, higher engineering costs, and longer design cycles.

Standard antenna design journey – iterative & long time to market:

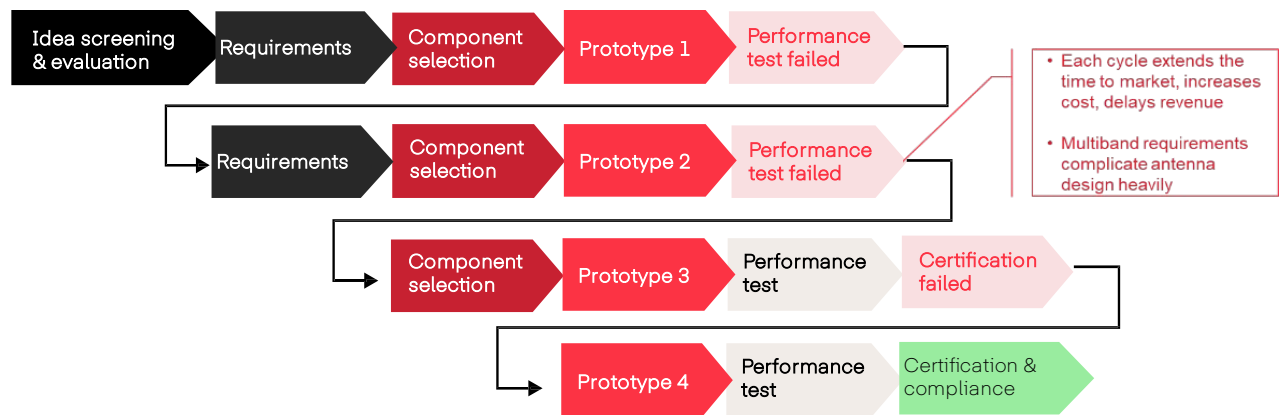

Virtual Antenna® design journey – shorter and with reduced risk:

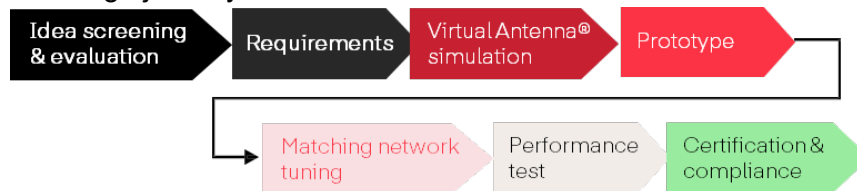

2.2. DESIGN STEPS WITH VIRTUAL ANTENNA® TECHNOLOGY

Considerations to keep in mind when designing with Virtual Antenna® technology.

- **Start antenna design early.** Consider what antenna component to use at the same time as choosing the RF module to ensure the optimal choice. The Ignion tool, Antenna Intelligence Cloud™, will provide you with the best performing option. Keep the antenna placement and the clearance space needed in mind, especially in cellular applications where the antenna needs more space.
- **Identify cellular bands needed.** Choosing a wider target than needed, could impact the antenna performance. Narrow bands will always perform better than wider bands.
- **Identify certification requirements** for your desired region and network carrier.

- **Consider impact of PCB size and objects in proximity of the antenna.** Antenna performance in the lower bands is defined by PCB size meanwhile objects like batteries, casing and materials in proximity will all influence the antenna response.

All the steps in this design guide can be done by a hardware engineer with the right tools. However, the Virtual Antenna® technology is backed by Ignion customer services where an experienced technical team is ready to assist in all stages of the design.

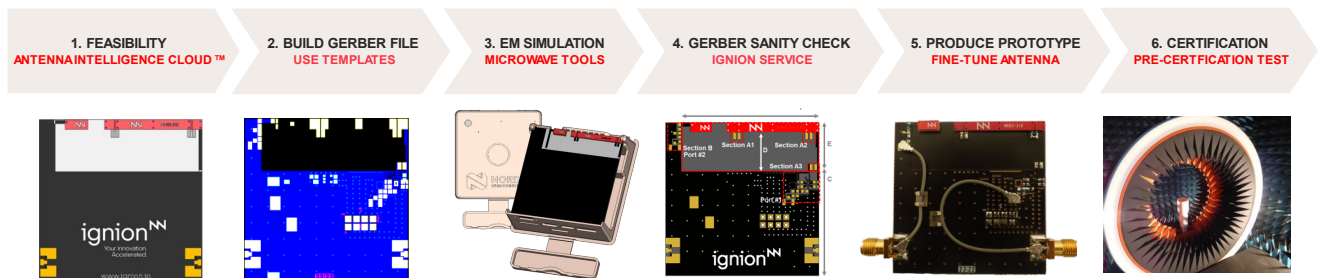

Figure 1 – Virtual Antenna® design journey for a successful cellular IoT solution.

Step 1 - Feasibility: The Antenna Intelligence Cloud™ provides feasibility results on a bare PCB in terms of reflection coefficient, total efficiency, and design recommendations such as antenna placement and clearance area.

Step 2 - Build Gerber file: Build the design files (Gerbers) with optimal antenna integration based on Ignion templates and design recommendations.

Step 3 - EM simulation: Design files are validated with an Electro-Magnetic (EM) simulation of the full device considering every component ensuring project requirements are met. Further allowing to evaluate design changes and their impact to the antenna performance.

Step 4 - Final Gerber sanity checks: Check ensuring that the antenna, matching network layout and other design recommendations on the final Gerber file the design guidelines before manufacturing.

Step 5 - Produce prototype and test: Verify performance results are aligned with expectations, fine-tune if needed.

Step 6 - Certification pre-test: Perform OTA tests to ensure the device is meeting certification requirements.

All these steps are shown in detail with specific examples in the following sections.

3. STEP BY STEP GUIDE WITH EXAMPLES

Throughout this section, an example design is used to go through each of the design journey steps. The example device characteristics are:

- PCB size of 100 mm x 50 mm.
- Cellular IoT bands at 698 MHz to 960 MHz and 1710 MHz to 2200 MHz
- GPS L1 band (1575 MHz).
- The board is implemented with a passive matching network.
- The antenna components used are TRIO mXTEND™ for the cellular bands and DUO mXTEND™ for GPS.
- Each of the solutions shown on this design guide are linearly polarized and has omnidirectional radiation patterns.
- The manufactured evaluation boards withstand temperatures from -40 to + 125 °C.
- Impedance: 50Ω.

The LTE-M frequency bands covered on this design guide are listed below:

Bands	Uplink (MHz)	Downlink (MHz)
B1	1920 – 1980	2110 – 2170
B10	1710 – 1770	2110 – 2170
B12	699 – 716	729 – 746
B13	777 – 787	746 – 756
B14	788 – 798	758 – 768
B15	1900 – 1920	2600 – 2620
B17	704 – 716	734 – 746
B18	815 – 830	860 – 875
B19	830 – 845	875 – 890
B2	1850 – 1910	1930 – 1990
B20	832 – 862	791 – 821
B23	2000 – 2020	2180 – 2200
B25	1850 – 1915	1930 – 1995
B26	814 – 849	859 – 894
B27	807 – 824	852 – 869
B28	703 – 748	758 – 803
B29	-	717 – 728
B3	1710 – 1785	1805 – 1880
B33		1900 – 1920
B34		2010 – 2025
B35		1850 – 1910
B36		1930 – 1990
B37		1910 – 1930
B39		1880 – 1920
B4	1710 – 1755	2110 – 2155
B44		703 – 803
B5	824 – 849	869 – 894
B6	830 – 840	875 – 885
B65	1920 – 2010	2110 – 2200
B66	1710 – 1780	2110 – 2200
B67	-	738 – 758
B70	1695 – 1710	1995 – 2020
B8	880 - 915	925 - 960
B85	698 - 716	728 - 746
B9	1749.9 - 1784.9	1844.9 - 1879.9
B68	698 – 728	753 – 783

Table 1 – Covered bands for the LTE-M bands with the TRIO mXTEND™ (NN03-310).

3.1. SIMULATIONS

3.1.1. FEASIBILITY – USING ANTENNA INTELLIGENCE CLOUD™

The feasibility evaluation starts with a simple and fast simulation on a bare PCB without any other non-RF components, casings, batteries, etc. These results are provided by Ignion's Antenna Intelligence Cloud™, a unique tool that delivers antenna performance results, suggested matching network topology, and BOM. By simply filling in the on-line form it is completed in minutes.

Below are the results extracted from the Antenna Intelligence Cloud™ submitted for this project using a 100 mm x 50 mm board for LTE-Cat M.

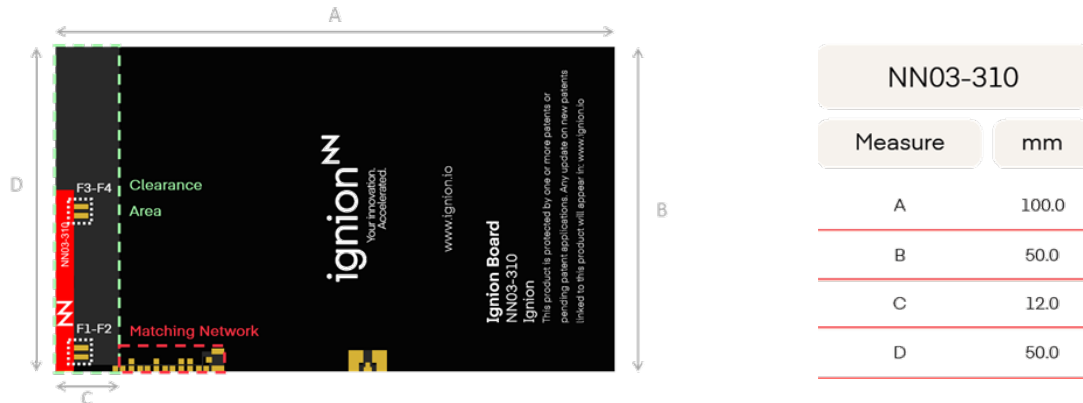
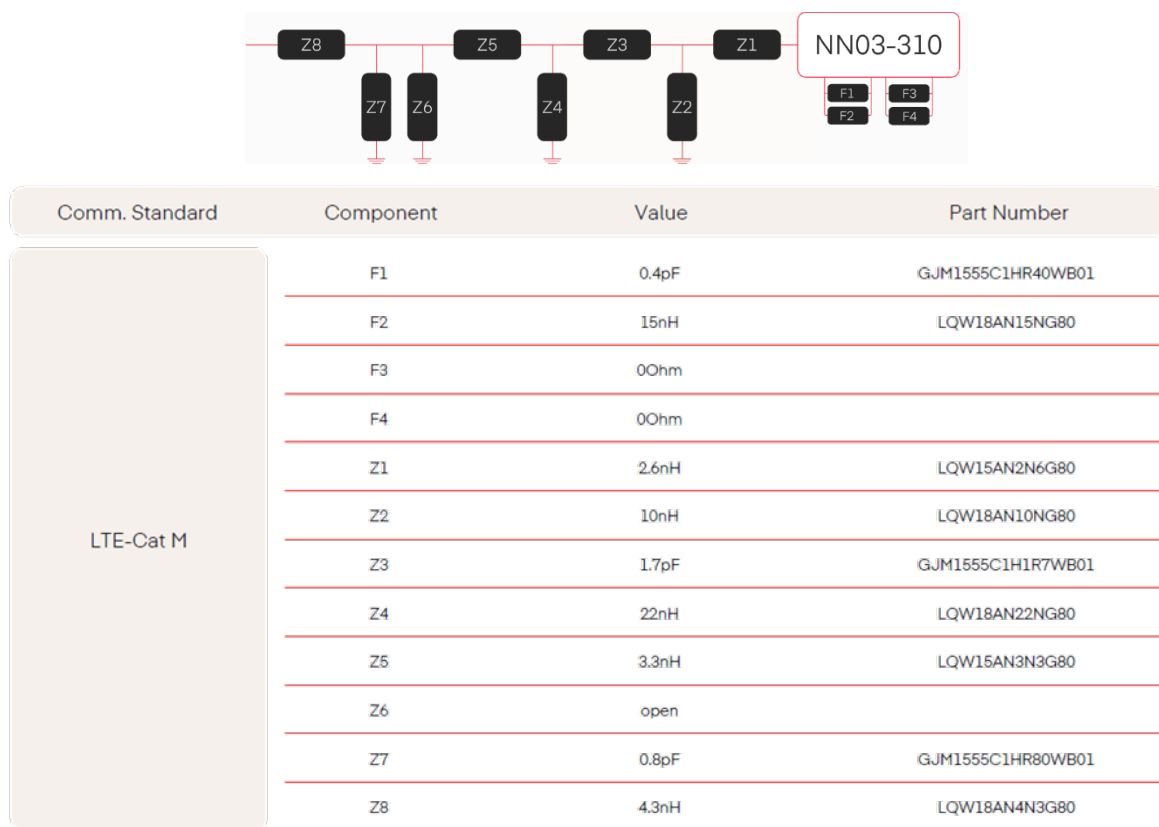

Figure 2 – PCB layout from the Antenna Intelligence Cloud™.



The electronic component values correspond with the Matching Network when implemented on a bare PCB. These values may need further tuning and optimization when additional elements such as batteries, plastic covers, connectors, displays, etc. are added to your final device.

Figure 3 – Matching network topology, and Bill of Materials from the Antenna Intelligence Cloud™.

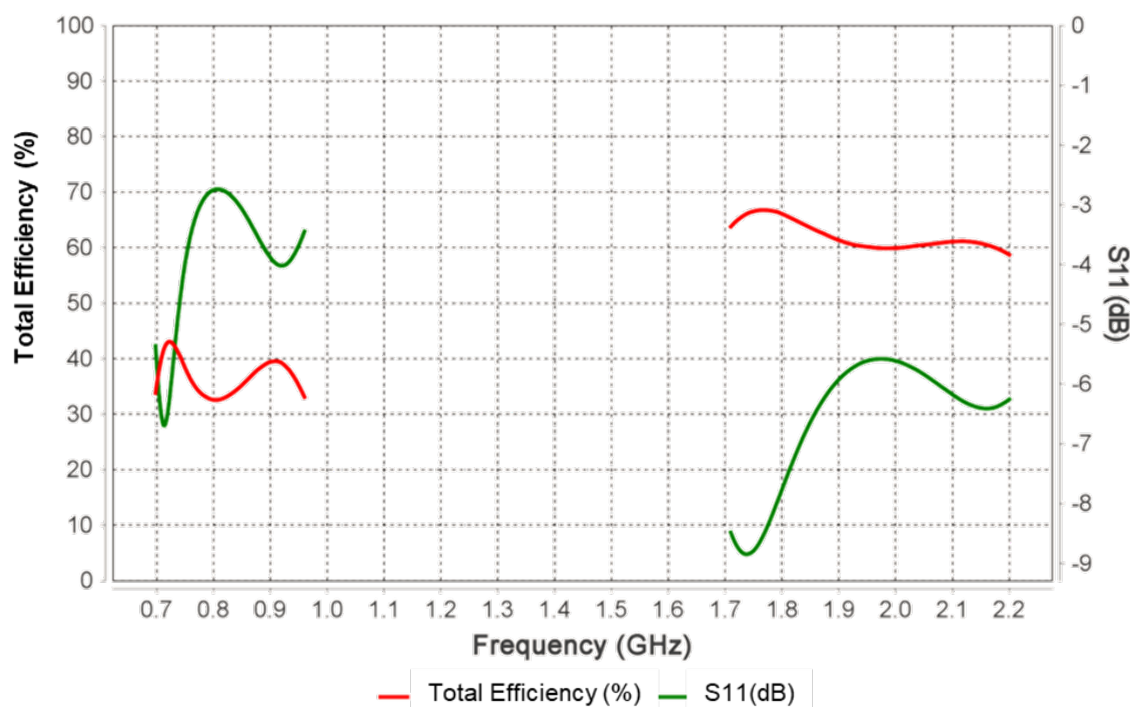

Figure 4 – Reflection Coefficient (dB) and Total Efficiency (%) from the Antenna Intelligence Cloud™.

The Antenna Intelligence Cloud™ results enables evaluation of whether the antenna performance is able of meeting the project expectations or if the solution needs some design adjustments.

3.1.2. BUILD YOUR DESIGN FILE

Build the device design file considering the design recommendations delivered in the Antenna Intelligence Cloud™ report. Virtual Antenna® components design files and as well as templates can be downloaded from Ignion website: <https://ignion.io/nordic/>.

To preserve the simulated antenna performance results in the physical prototype the following design recommendations should be considered.

1. **Antenna placement:** Place the antenna as far as possible from other components, such as LCDs, batteries, connectors, especially those components and covers with metallic characteristics (see suitable placement in Figure 5).
2. **Clearance area:** Keep the clearance area around the antenna component as recommended in Figure 5. The clearance area must be free from electronic components, traces and ground plane in all PCB layers including the underside of the PCB directly underneath the mounted antenna area. As a general rule of thumb, the larger the clearance area the better the performance.
3. **PCB layers:** Ensure a continuous ground plane layer in at least one layer of your PCB design. Avoid any ground plane or conductive trace underneath the matching network pads area at a distance shorter than 1 mm from it.

4. **Matching network:** Arrange pads for all the matching networks to host 0402/0603 SMD components if possible. Place pads as close as possible to the antenna feed point and within the ground plane area to enable an effective tuning of the matching networks components throughout your design. Use preferably **high Q and tight tolerance** matching network components.
5. **Transmission line and RF chip:** Design your transmission line connecting the matching network to your RF chip (see scheme connecting in Figure 2) so that its characteristic impedance is 50Ω. The output impedance of your RF chip must feature 50Ω as well. Locate your RF chip as close as possible to the matching network to reduce the losses introduced by the transmission line.

3.1.3. PERFORM ELECTRO-MAGNETIC SIMULATIONS

Perform Electro-Magnetic (EM) simulations on the full device considering every component (Batteries, casings, other non-RF components) to simulate their influence on antenna performance. You can download the design info pack from the Ignion website that includes 2D files (.dxf and Gerber files), 3D files (.stp, and CST files), Sparam files for the Ignion products including Virtual Antenna®, Evaluation Boards, and all the necessary info to do electromagnetic simulations.

Ignion also provides this as a service ensuring customer requirements and optimized antenna integration. An electromagnetic simulation of a 100 mm x 50 mm board is done where both the reflection coefficient and the corresponding total efficiency are shown.

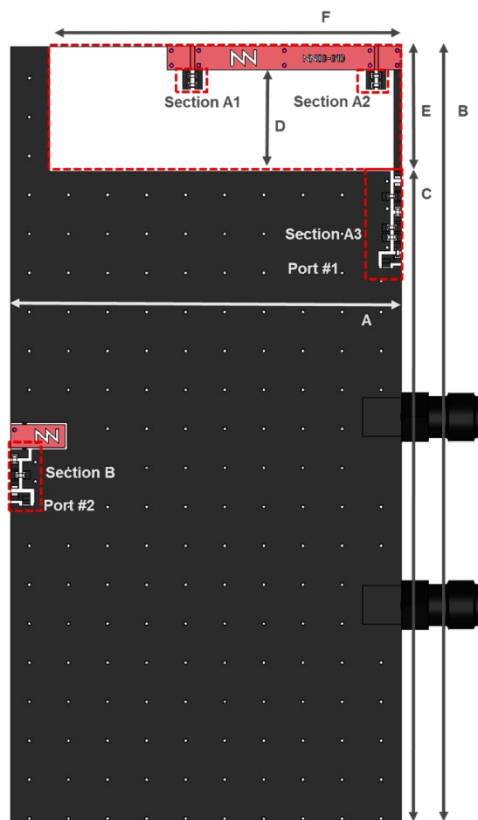

Measure	mm
A	50
B	100
C	84
D	13
E	16
F	45

D: Distance between the TRIO mXTEND™ antenna booster and the ground plane.

Material: The evaluation board is simulated on FR4 substrate. Thickness is 1 mm.

Figure 5 – Evaluation Board simulated with all the components for the different solutions from LTE-M (698 MHz to 960 MHz, from 1710 MHz to 2200 MHz) with the TRIO mXTEND™ and from GPS L1 (1575 MHz) with the DUO mXTEND™.

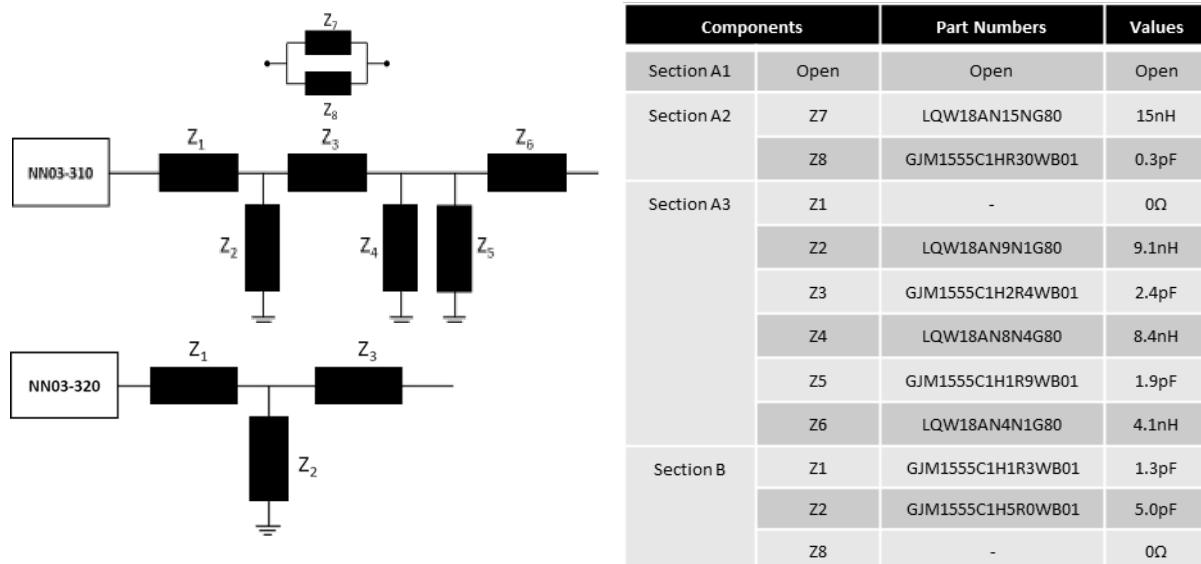

Figure 6 – Topology and Bill of Materials of matching network mounted for the solutions from LTE-M (698 MHz to 960 MHz, from 1710 MHz to 2200 MHz) with the TRIO mXTEND™ and from GPS L1 (1575 MHz) with the DUO mXTEND™.

3.1.4. VERIFY ANTENNA IS OPTIMALLY TUNED - REFLECTION COEFFICIENT

The reflection coefficients for LTE-M (from 698 MHz to 960 MHz, and from 1710 MHz to 2200 MHz) with the TRIO mXTEND™ and GPS L1 (1575 MHz) with the DUO mXTEND™ are shown by simulation. Note that, in case of any mismatch, the solution can be easily re-tuned just adjusting the matching network components ensuring the antenna response is matched for the desired frequency bands.

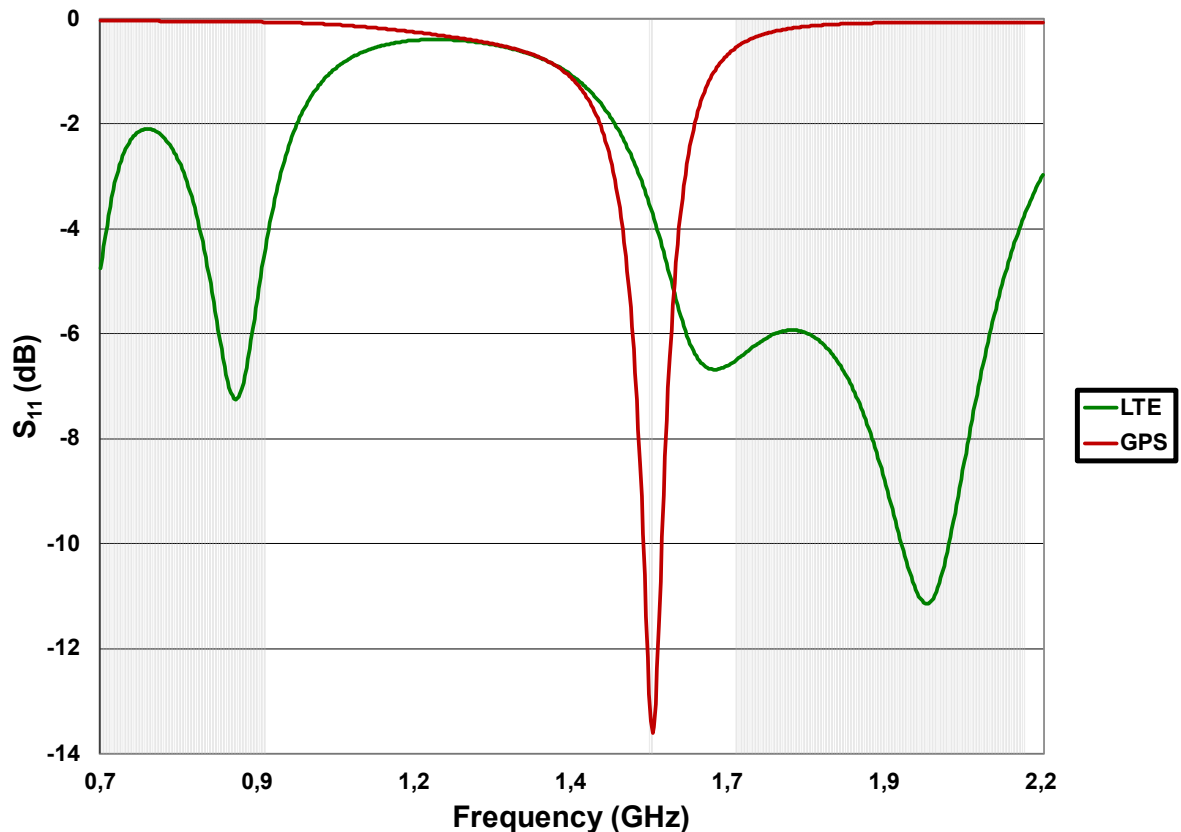

Figure 7: Reflection coefficients (dB) for the 698 – 960 MHz frequency range, the 1710 – 2200 MHz frequency range and for the 1575MHz band from Figure 10.

3.1.5. VERIFY DESIRED TOTAL EFFICIENCY

The total efficiency is obtained from the previous reflection coefficient results from LTE-M (698 MHz to 960 MHz, from 1710 MHz to 2200 MHz) with the TRIO mXTEND™ and from GPS L1 (1575 MHz) with the DUO mXTEND™.

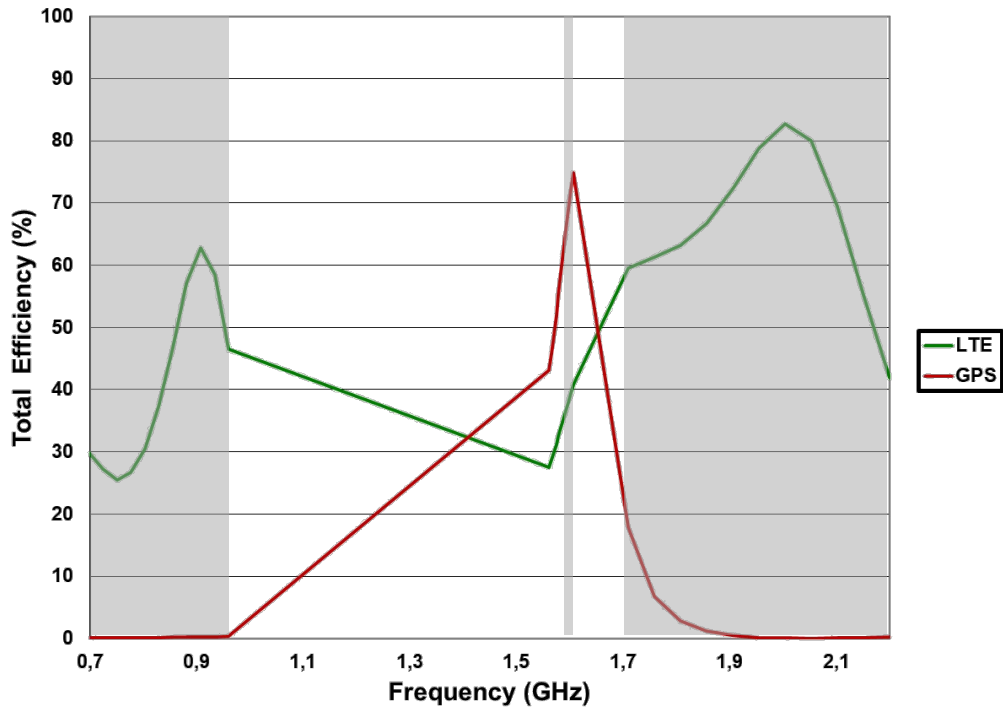

Figure 8 - Total efficiency for the 698 – 960 MHz frequency range, the 1710 – 2200 MHz frequency range and for the 1575MHz band Figure 10.

3.2. PROTOTYPING

Produce the physical prototypes and ensure that the simulated performance results are aligned with lab measurements. The Gerber files must be built following the design criteria from simulations to achieve results.

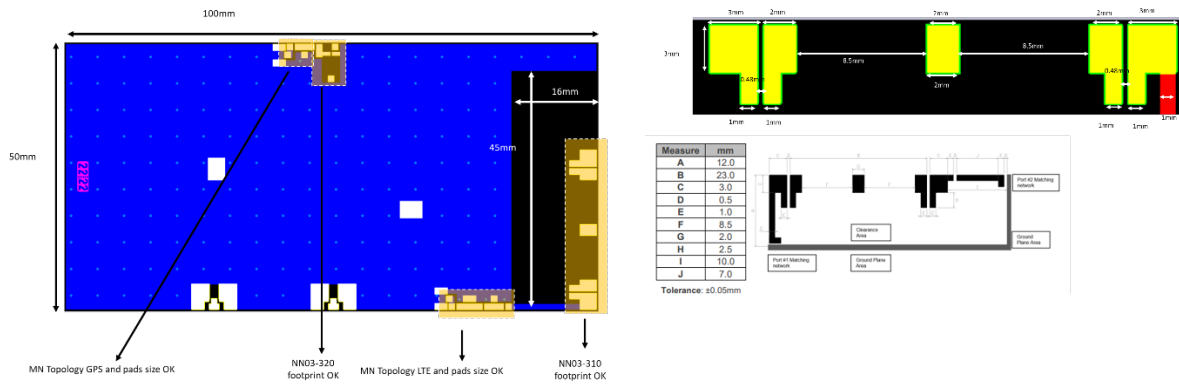

Figure 9 – Example of a Gerber review before manufacturing.

As it is shown in Figure 10, the evaluation board is manufactured following the same criteria as per the simulation stage.

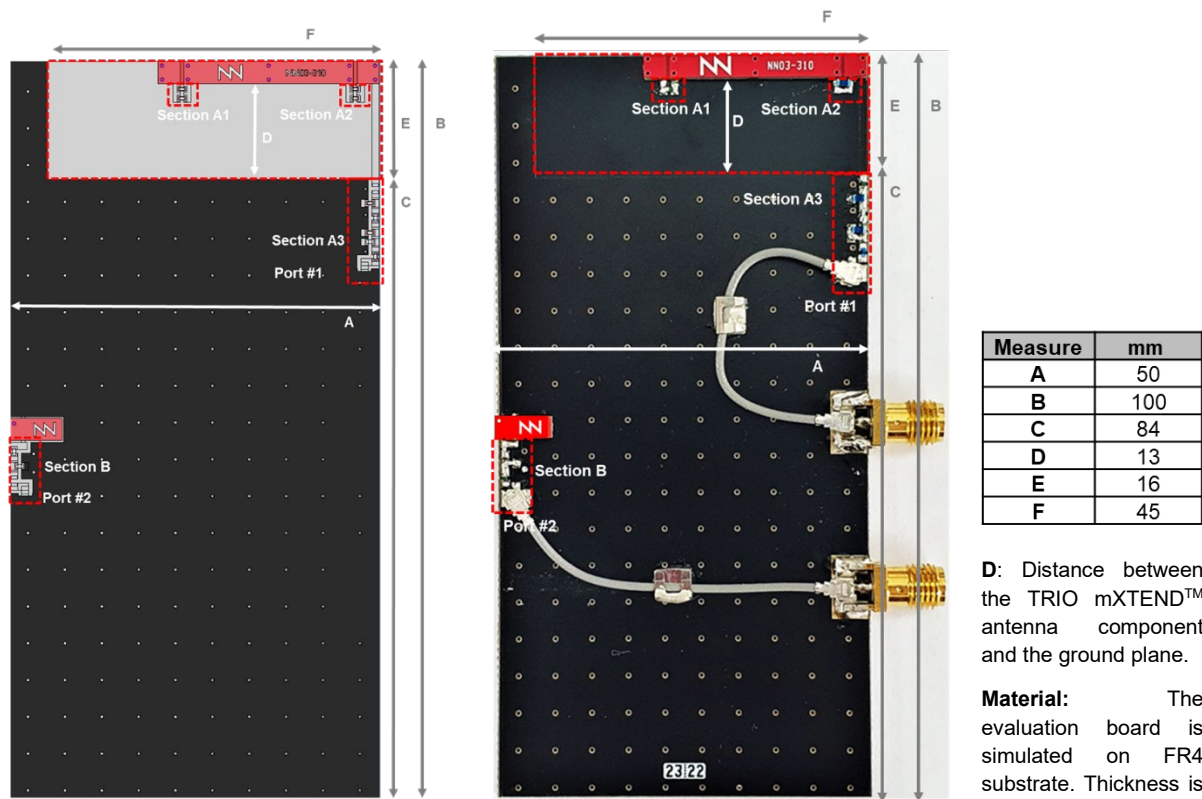

Figure 10 Evaluation Boards from simulation (left) to real device (right).

3.3. LAB MEASUREMENTS

Once the prototype has been manufactured, the antenna performance can be physically measured in a lab with a VNA and an anechoic chamber. In this section, the manufactured PCB is measured to validate the performance results between the simulation and prototyping stages. The following set-up integrates the TRIO mXTEND™ and the DUO mXTEND™ chip antenna components with a SMA connector so that VSWR and total efficiency can be tested as it is shown in Figure 10.

3.3.1. TOTAL EFFICIENCY MEASURED IN LAB

	698-748 MHz	746-803 MHz	791-849 MHz	824-894 MHz	880-960 MHz	1710-2200 MHz	GPS 1575 MHz
Average Efficiency (%)	40.4	34.0	33.5	39.3	50.5	62.1	67.5

Table 2 – Total efficiency for the LTE-M bands with the TRIO mXTEND™ (NN03-310) and the GPS L1 band with the DUO mXTEND™ (NN03-320).

3.3.2. MEASURED REFLECTION COEFFICIENT

The reflection coefficients for both solutions, LTE-M (698 MHz to 960 MHz, 1710 MHz to 2200 MHz) and GPS L1 band (1575 MHz) are shown from simulation (dotted line) and from real measurements (solid line). As it can be seen, the similarities between both stages are in good agreement, the responses are matched in the desired bands.

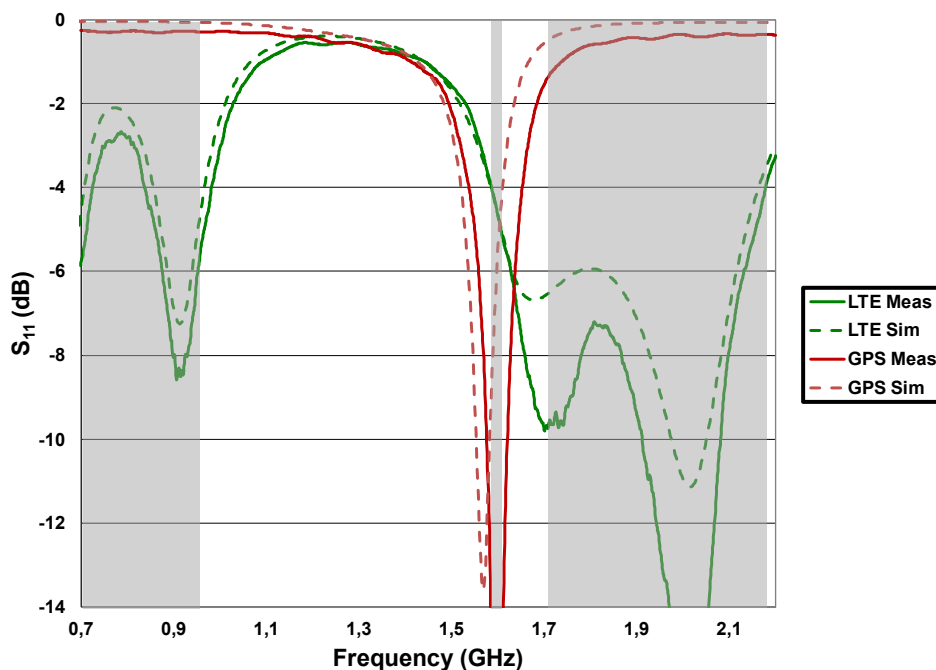

Figure 11: Reflection coefficient (dB) for LTE-M (698 MHz to 960 MHz, 1710 MHz to 2200 MHz) and GPS L1 band (1575 MHz) comparison from the Evaluation Board both simulated and measured (Figure 10).

3.3.3. MEASURED TOTAL EFFICIENCY & TUNING

The total efficiency (%) for both solutions, LTE-M (698 MHz to 960 MHz, 1710 MHz to 2200 MHz) and GPS L1 band (1575 MHz) are shown from simulation stage (dotted line) and from real measurements (solid line). As it can be seen, both simulated and measured results are well aligned.

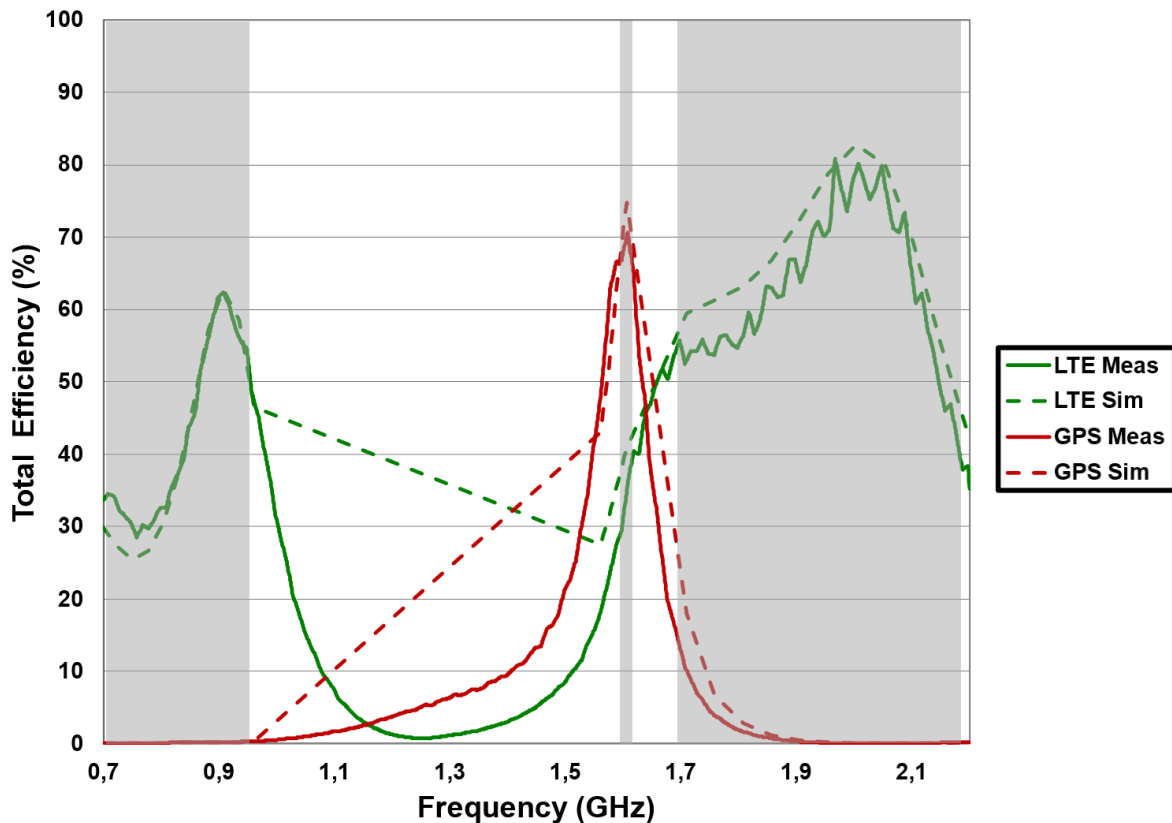

Figure 12 Total efficiency (%) for LTE-M (698 MHz to 960 MHz, 1710 MHz to 2200 MHz) and GPS L1 band (1575 MHz) comparison from the Evaluation Board both simulated and measured (Figure 10).

Even though the measurement results are aligned with simulation, the Virtual Antenna® capabilities of further tuning enables optimizations at a later stage if needed. **Figure 13** Total efficiency for LTE-M (698 MHz to 960 MHz, 1710 MHz to 2200 MHz) and GPS L1 band (1575 MHz) from the Evaluation Board (Figure 10).

shows the measurement results before and after the matching network was optimized improving B12 (699 MHz – 746 MHz), B4 (1710 MHz – 1755 MHz) and B2 (1850 MHz– 1910 MHz).

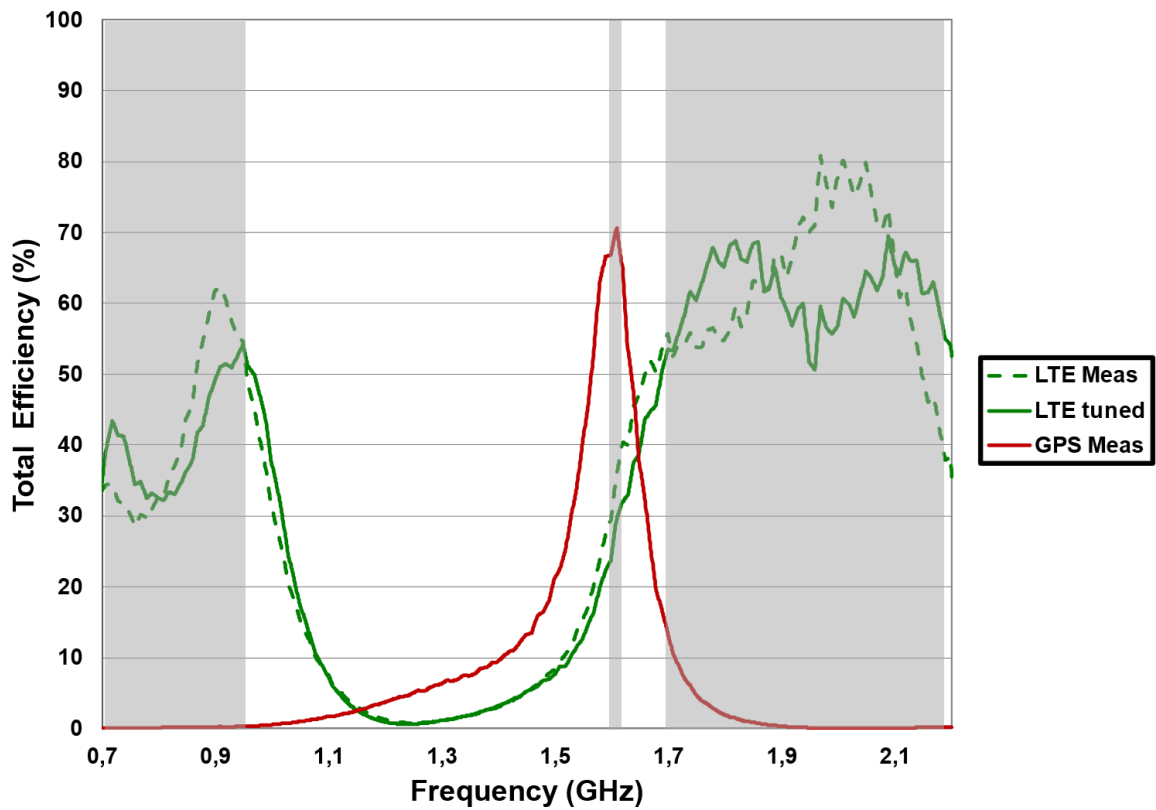
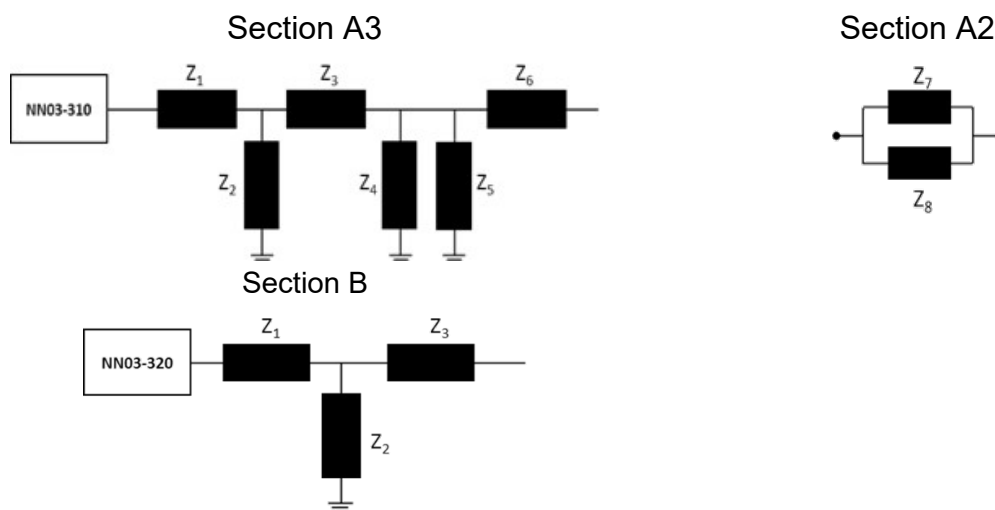

Figure 13 Total efficiency for LTE-M (698 MHz to 960 MHz, 1710 MHz to 2200 MHz) and GPS L1 band (1575 MHz) from the Evaluation Board (Figure 10).



Components		Part Numbers		Values		Components		Part Numbers		Values	
Section A1	Open	Open		Open	Section A1	Open	Open		Open		
Section A2	Z7	LQW18AN15NG80		15nH	Section A2	Z7	LQW18AN15NG80		15nH		
	Z8	GJM1555C1HR30WB01		0.3pF		Z8	GJM1555C1HR30WB01		0.3pF		
Section A3	Z1	-		0Ω	Section A3	Z1	-		0Ω		
	Z2	LQW18AN9N1G80		9.1nH		Z2	LQW15AN7N2G80		7.2nH		
	Z3	GJM1555C1H2R4WB01		2.4pF		Z3	GJM1555C1H2R5WB01		2.5pF		
	Z4	LQW18AN8N4G80		8.4nH		Z4	LQW18AN8N2G80		8.2nH		
	Z5	GJM1555C1H1R9WB01		1.9pF		Z5	GJM1555C1H1R5WB01		1.5pF		
	Z6	LQW18AN4N1G80		4.1nH		Z6	LQW15AN3N0G80		3.0nH		
Section B	Z1	GJM1555C1H1R3WB01		1.3pF	Section B	Z1	GJM1555C1H1R3WB01		1.3pF		
	Z2	GJM1555C1H5R0WB01		5.0pF		Z2	GJM1555C1H5R0WB01		5.0pF		
	Z8	-		0Ω		Z8	-		0Ω		

Figure 14 – Topology and Bill of Materials of matching network mounted for TRIO mXTEND™ covering LTE-M (698 MHz to 960 MHz, 1710 MHz to 2200 MHz) and for the DUO mXTEND™ covering GPS L1 band (1575 MHz) from the Evaluation Board (Figure 10). In green the changes over the previous solution to better match some bands.

As mentioned in the design steps with Virtual Antenna® (2.1) is advisable to be aware of the bands that need to surpass certifications. In the next section, an example of certification stage is shown with the operator requirements.

3.4. MEETING CERTIFICATION REQUIREMENTS

The Virtual Antenna® technology enables developers to ensure meeting certification requirements from the beginning of the IoT device design journey. If any changes in certification requirements appear after the initial design, the antenna solution can be easily tuned to any desired frequency band without needing to change the antenna component.

3.4.1. IDENTIFY CERTIFICATION REQUIREMENTS

The certification requirements are obtained from the cellular operator and vary both by region as well as per device characteristics. For this example, we consider TRP requirements from AT&T for a small device operating on LTE-M bands (Source: AT&T: Radiated Performance Requirements version 1.6). As per AT&T requirements, small form factors belong to devices shorter than 107mm in the longest direction (the example board used is 100 mm x 50 mm).

Band	Minimum TRP Requirement Power Class 3	Minimum TRP Requirement Power Class 5
2	+12.0 dBm	+9.0 dBm
4	+12.0 dBm	+9.0 dBm
12	+10.0 dBm	+7.0 dBm

Figure 15 - LTE-M Requirements for Small Form Factors: Free-Space.

3.4.2. ESTIMATE TOTAL RADIATED POWER (TRP) AND COMPARE TO CERTIFICATION REQUIREMENT

The estimated TRP results are calculated using Equation 1 considering 23dBm (Power class 3) of output power from the Nordic NRF9160 RF module. As it is seen in Figure 15 there are 2 classes referring to output power from Nordic NRF9160 RF module. Power class 3 means that module provides 23dBm of output power. Power class 5 provides 20 dBm.

$$\text{Estimated TRP (dBm)} = \text{Output power (dBm)} + \text{Total Efficiency (dB)}$$

Equation 1 - Estimated TRP (dBm) calculated from RF Module output power (dBm) combined with antenna solution Total efficiency (dB).

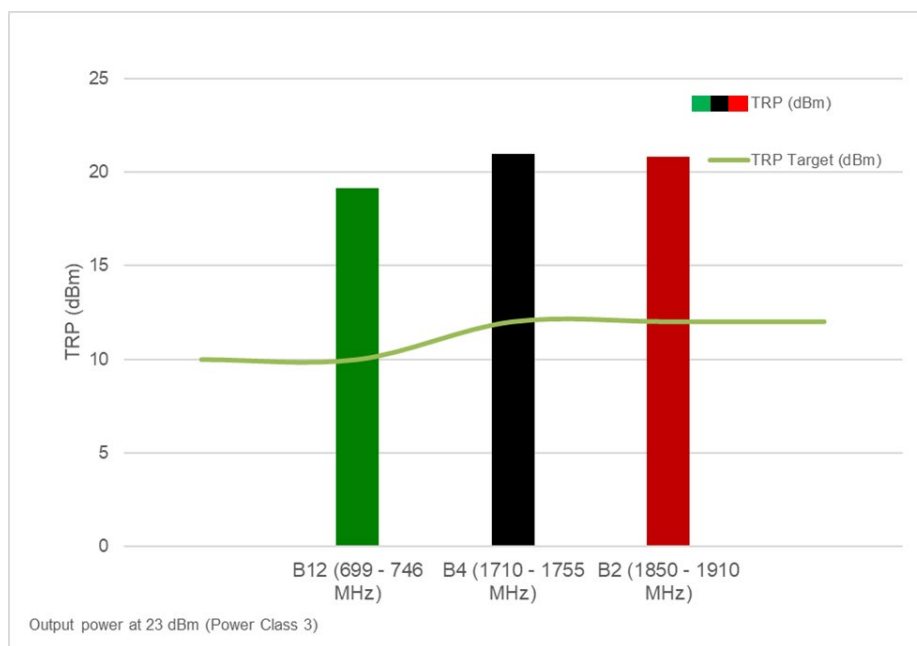

Figure 16 – Estimated TRP (dBm) from the Evaluation Board (**Figure 10**). TRP requirements are extracted from AT&T Radiated Performance Requirements for IoT Devices referring to small form factor devices for LTE-M Requirements in Free-Space.

As shown the certification targets are fulfilled with great margin and should be expected to easily pass certification tests.

3.4.3. PRE-CERTIFICATION LAB TEST - VERIFY YOUR DEVICE TRP PERFORMANCE

On the final physical prototype, perform OTA (Over-the-Air) test measurements of conducted power, conducted sensitivity, TRP and TIS to prepare and ensure the device will pass the official certification tests.

If needed the matching network can be further optimized and design can be adjusted to further improve performance.

4. PCB SIZE INFLUENCE

PCB size and total efficiency are directly correlated, and to show the relation the TRIO mXTEND™ is measured in 5 different evaluation boards sizes within the 698-960 MHz and 1710-2200 MHz frequency range and the DUO mXTEND™ at GPS L1 band (1575 MHz). Please note that the TRIO mXTEND™ can cover a much wider range of communication standards such as GNSS and Wi-Fi/BT through the same antenna component.

4.1. 5 REFERENCE BOARD FORM FACTORS

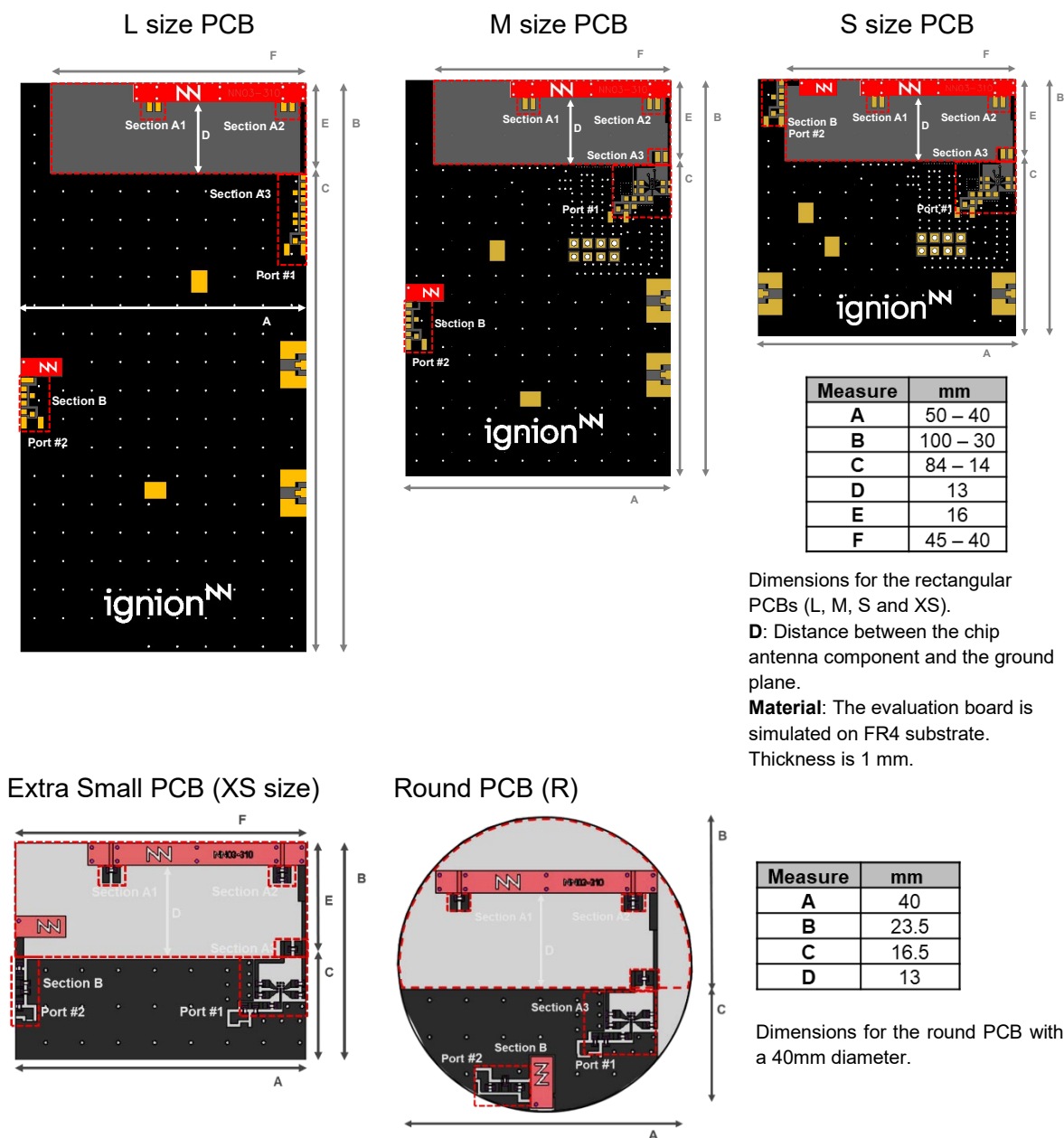

Dimensions for the rectangular PCBs (L, M, S and XS).

D: Distance between the chip antenna component and the ground plane.

Material: The evaluation board is simulated on FR4 substrate. Thickness is 1 mm.

Dimensions for the round PCB with a 40mm diameter.

Figure 17 – Evaluation boards with different simulated PCB dimensions, ranging from 100 mm x 50 mm down to 30 mm x 40 mm squared form factor and a 40 mm diameter PCB, providing operation from 698 MHz to 960 MHz and from 1710 MHz to 2200 MHz with the TRIO mXTEND™ and GPS L1 band (1575 MHz) with the DUO mXTEND™.

The following results cover a wide scope of PCB sizes, ranging from 100 mm x 50 mm down to 30 mm x 40 mm squared form factor and a 40 mm diameter PCB. The L-size PCB is with a passive matching network, and it is measured on the real device. The M-size PCB and S-size PCB are implemented in an active solution (that will be introduced in section 4.3) and measured on real devices as well. The XS-size and the round PCB size are also implemented in an active solution but by simulation.

4.2. TOTAL EFFICIENCY vs BOARD SIZE

The total efficiency (%) of each of the PCBs shown in Figure 17 is evaluated. The L size PCB is using a passive matching network and the rest of the PCBs are using an active matching network. Total efficiency (%) for each of the switch states overlapped is shown in Figure 18.

	PCB dim (mm)	698 – 748 MHz	746- 803 MHz	791- 849 MHz	824- 894 MHz	880- 960 MHz	1710-2220 MHz	GPS 1575 MHz
Total Efficiency (%)	L size 100x50	40.4	34.0	33.5	39.3	50.5	62.1	67.8
	M size 75x50	22.2	32.9	42.9	39.5	36.8	52.3	58.7
	S size 50x50	16.5	24.6	28.3	25.6	20.5	48.0	66.8
	Extra S 30x40	5.3	8.2	12.2	17.1	18.5	35.0	43.2
	Round Diam40	3.9	7.3	10.6	14.8	21.4	31.7	28.5

Table 3 – Total efficiency for the LTE-M bands with the TRIO mXTEND™ (NN03-310) and the GPS L1 band with the DUO mXTEND™ implemented on 5 PCB sizes.

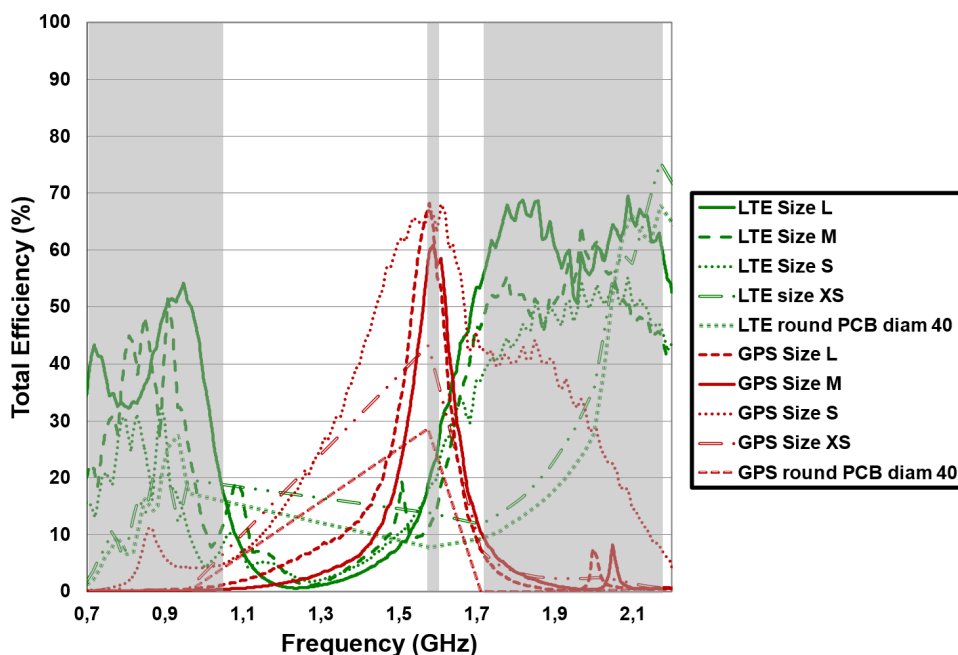

Figure 18 - Total efficiency (%) comparison between different PCB dimensions as it is shown in Figure 17.

4.3. HIGH PERFORMANCE IN SMALL DEVICES

When designing small IoT devices, meeting range and radiation efficiency requirements can be challenging as the total efficiency is impacted by PCB size. To further improve the antenna performance a smart adaptive matching network can be implemented by introducing a switching architecture, enabling a single antenna system to transmit at different frequency bands. A so-called active solution can provide a significant improvement on those bands where the performance gets affected by the small PCB dimensions. Virtual Antenna® technology is ideal for use with active matching network systems including switches due to being non-resonant which provides a major level of flexibility to tune and tailor the frequency response to any required frequency range without being constrained by the natural resonances of other SMD antennas.

4.3.1. PASSIVE COMPARED TO ACTIVE MATCHING NETWORK

As an example, a small PCB with 50 x 50 mm dimension is used implemented both with a passive matching network as well as with an active matching network antenna architecture operating at 698 MHz – 960 MHz and 1710 MHz – 2200 MHz with the TRIO mXTEND™ and GPS 1575MHz with DUO mXTEND™ (NN03-320). It is seen that the active matching network with a switch improves antenna performance in each of the covered frequency bands compared with the passive solution (Figure 19).

The cellular frequency band of operation is automatically controlled by RF Module through a MIPI interface. Such interface controls the Qorvo SP4T. In this application note six matching networks designed with the NI-AWR software are used to match different bands of LTE.

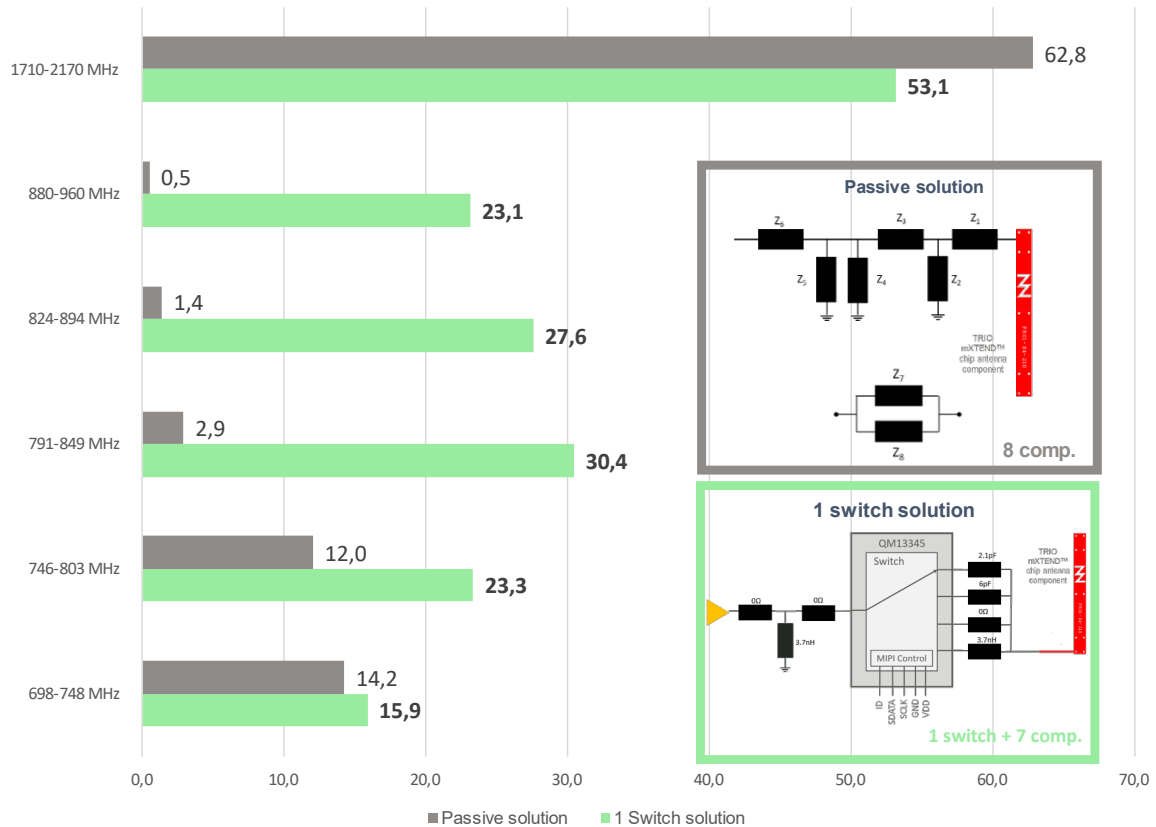

Figure 19 – Comparison between achieved Total efficiency (%) with a passive solution (gray trace) and an active solution (green trace) on a 50 mm x 50 mm PCB.

As seen in the image above, the active solution (green trace) provides significantly better performance in the low bands of LTE than the passive solution (gray trace), by significantly improving those bands where the performance gets affected by the smaller PCB.

Including a switch in the matching network design also allows designers to individually optimize the device matching networks and if needed, easily adjust the design to include additional/other LTE bands.

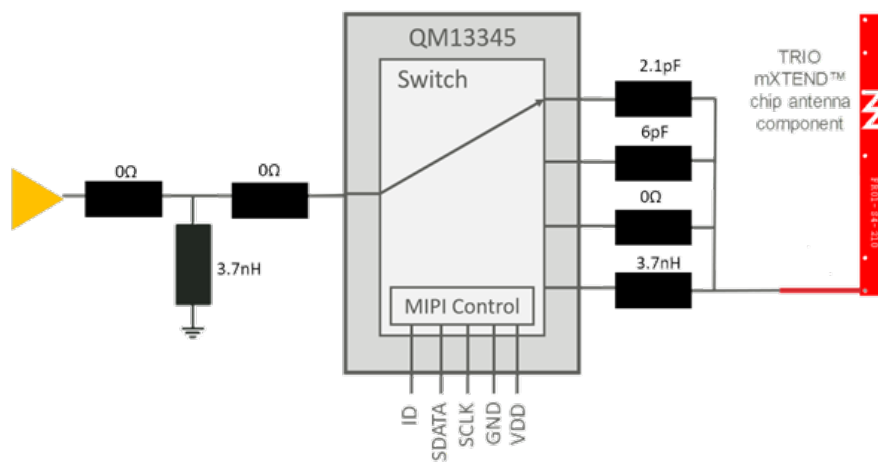
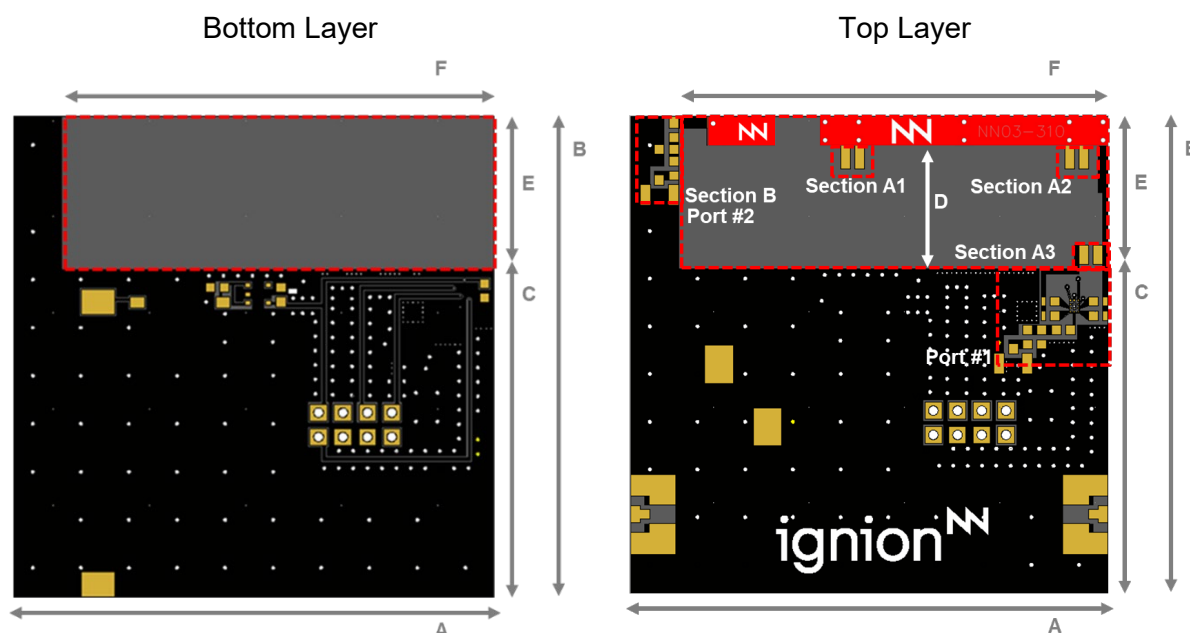

Figure 20 – TRIO mXTEND™ chip antenna component connected through the switch QM13345 from Qorvo and the matching network.

4.3.2. RECOMMENDATIONS FOR ACTIVE MATCHING NETWORK ARCHITECTURE

Follow these design recommendations to optimize the performance in a small device with active matching network.

- Minimum recommended PCB size: 50 mm x 50 mm.
- Keep one continuous ground plane layer.
- Place the TRIO mXTEND™ and the DUO mXTEND™ antenna components close to a corner of the PCB.
- Include a feeding line 1 mm width as close as possible to a PCB corner.
- Leave a ground clearance (area free of any component or conductive traces) of at least 45 mm x 16 mm. This clearance area applies to all layers.
- Include pads compatible with 0402 and 0603 SMD components for the LTE matching networks as close as possible to the feeding point (see next section for details about the matching network).



Measure	mm
A	50
B	50
C	34
D	13
E	16
F	45

D: Distance between both Virtual Antenna® components and the ground plane.

Material: The evaluation board is simulated on FR4 substrate. Thickness is 1 mm.

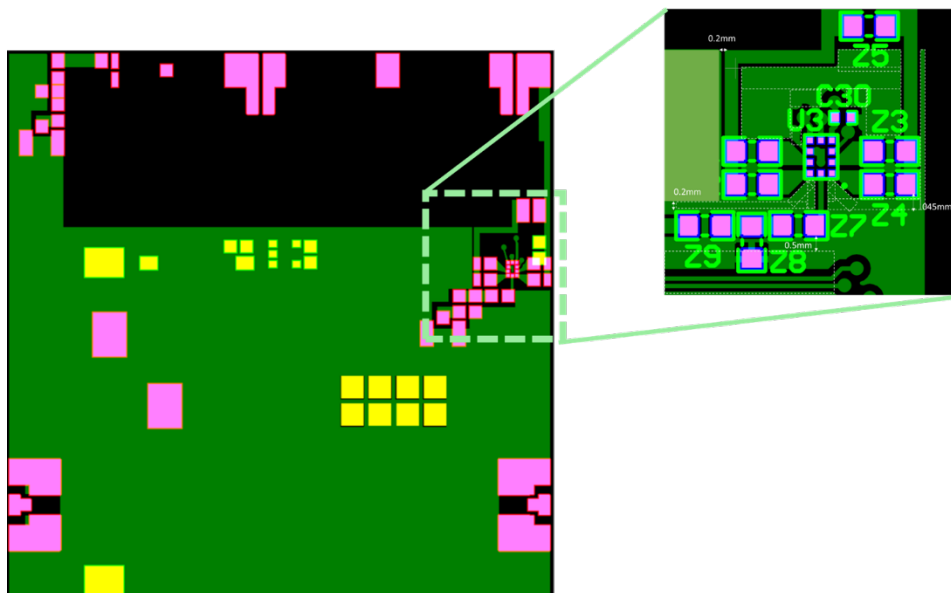

Figure 21 – Evaluation board of 50 x 50 mm dimensions providing operation from 698 MHz to 960 MHz and from 1710 MHz to 2200 MHz with the TRIO mXTEND™ and GPS L1 band (1575 MHz) with the DUO mXTEND™ including a smart and adaptative active matching network.

4.3.3. TOTAL EFFICIENCY WITH ACTIVE MATCHING NETWORK

The total efficiency of the small size, 50 mm x 50 mm, PCB with active matching network shows good performance from 698MHz to 960MHz and from 1710 MHz to 2200 MHz with the TRIO mXTEND™ (NN03-310) as well as GPS L1 1575MHz working simultaneously with the DUO mXTEND™ (NN03-320).

	698-748 MHz	746-803 MHz	791-849 MHz	824-894 MHz	880-960 MHz	1710-2200 MHz	GPS 1575 MHz
Average Efficiency (%)	16.5	24.6	28.3	25.6	20.5	48.0	66.8

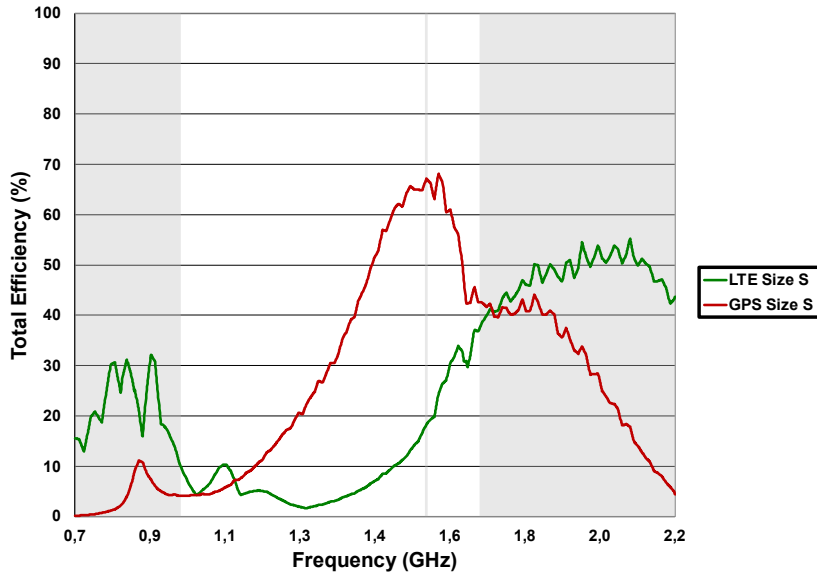

Figure 22 – Total efficiency for the 50 mm x 50 mm PCB with active matching network for LTE-M bands with the TRIO mXTEND™ (NN03-310) and the GPS L1 band with the DUO mXTEND™.

4.3.4. CERTIFICATION REQUIREMENTS EXAMPLE CALCUATION

Given the efficiency results obtained for the small size board, the total radiated power is evaluated. TRP requirements are extracted from AT&T Radiated Performance Requirements for IoT Devices (Radiated Performance Requirements version 1.6). The results show the small size with active matching network should be expected to easily pass these certification requirements.

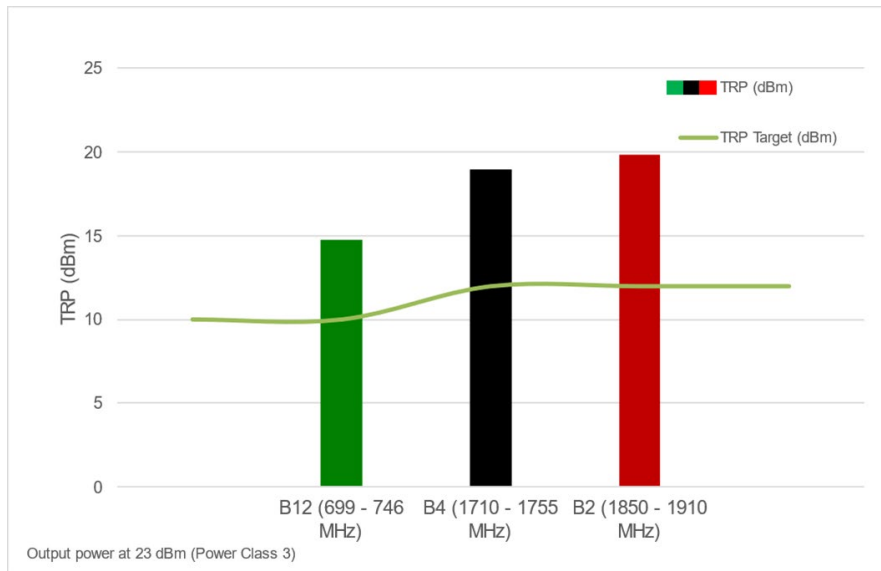
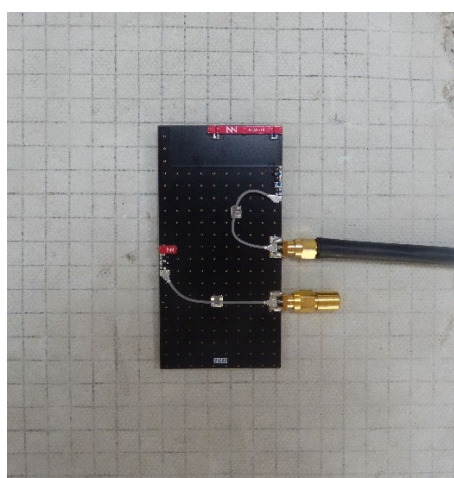

Figure 23 Estimated TRP (dBm) from the 50 mm x 50 mm PCB with active matching network. TRP requirements are extracted from AT&T Radiated Performance Requirements for IoT Devices referring to small form factor devices for LTE-M Requirements in Free-Space.

5. INFLUENCE BY MATERIALS IN PROXIMITY

IoT applications come in a wide variety of form factors and must work in different environmental conditions. Some devices are placed near materials that affect their wireless performance like walls, containers, animals, and pallets for logistic purposes. This section shows how this proximity impacts the antenna performance in practice. The materials assessed are concrete, wood, body phantom, and metal. Five different distances between the L size PCB of 100mm x 50mm and the surrounding material are evaluated: 20mm, 15mm, 10mm, 5mm and 0mm. The matching network used in this analysis remains the same as the L size in free space, to evaluate the shifting in frequency, if any, introduced by each material.



Concrete

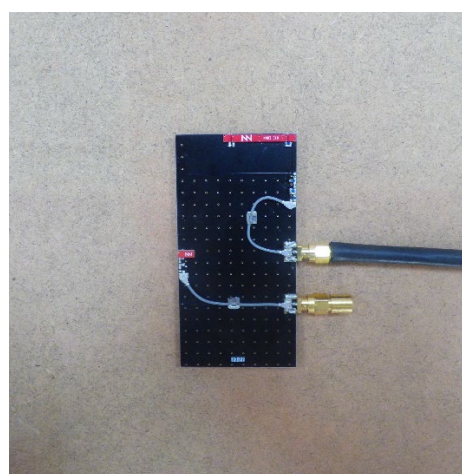

Wood

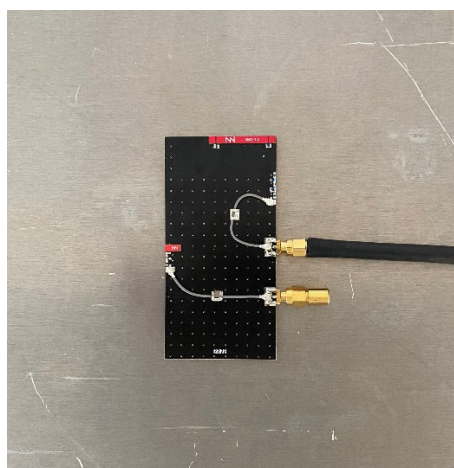

Metal

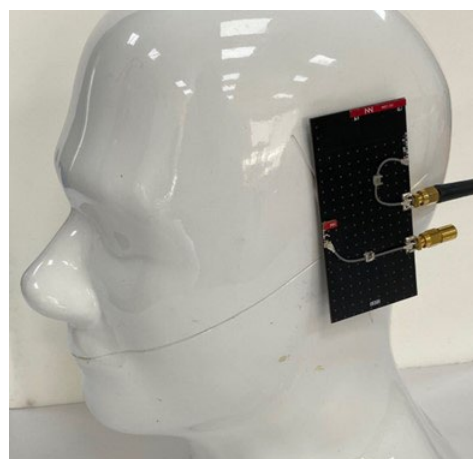

Body Phantom

Figure 24 - Set-ups analyzed considering four different materials: concrete, wood, metal and body phantom. Distances evaluated: 20 mm, 15 mm, 10 mm, 5 mm and 0 mm. The Evaluation Board used is from Figure 10.

The materials in the surroundings of any radiating system can affect the performance, detuning the antenna response in terms of reflection coefficient as well as radiation efficiency. With the Virtual Antenna® technology the antenna response can easily be tuned allowing IoT designers to optimize the design for the environmental effects. The results gathered in the next sections show how different materials affect the antenna performance in VSWR and total efficiency (%)

depending on the distance between the device and the underlying material (wood, concrete, body, metal).

5.1. WOOD – NO SIGNIFICANT EFFECT

The antenna performance in presence of wood hardly changes as it is shown in Figure 25 and Table 4. The only noticeable effect is a little drop in the high LTE-M bands, due to material insertion of losses. It can be concluded that the antenna is highly robust to this material.

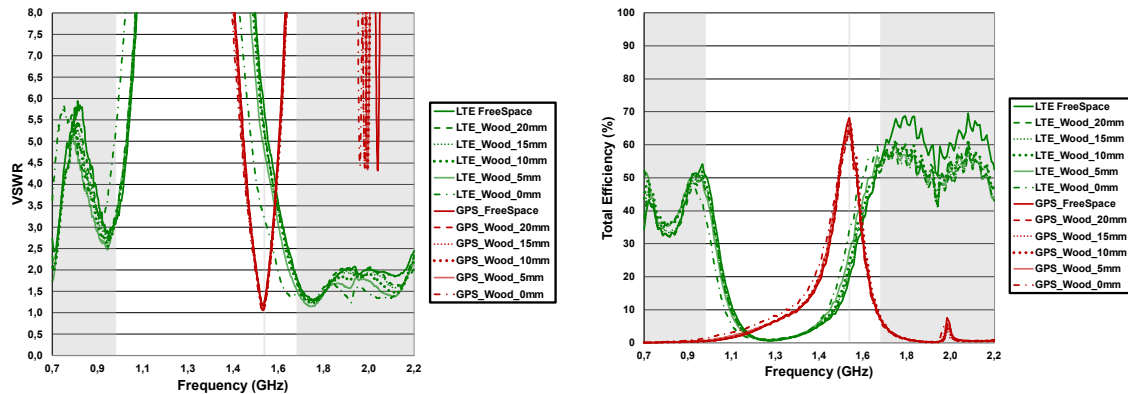

Figure 25 – VSWR & Total efficiency for the different bands covered by the L size board from Figure 10 and placed in close proximity to wood.

	Wood PCB (100 x 50)	698 – 748 MHz	746-803 MHz	791-849 MHz	824-894 MHz	880-960 MHz	1710-2220 MHz	GPS 1575 MHz
Average Efficiency (%)	Free Space	40.4	34.0	33.5	39.3	50.5	62.1	67.5
	Distance 20mm	41.8	34.1	33.2	38.0	47.3	52.8	63.4
	Distance 15mm	43.3	35.1	34.3	39.3	48.5	52.8	63.6
	Distance 10mm	45.9	37.2	36.9	41.9	50.0	54.9	66.9
	Distance 5mm	46.6	36.1	36.9	42.4	49.1	53.4	65.0
	Distance 0mm	44.7	35.5	37.2	42.4	45.2	54.3	63.6

Table 4 - Total efficiency (%) in presence of wood for LTE bands with the TRIO mXTEND™ and GPS L1 band with DUO mXTEND™ at 5 distances between the PCB and the material.

5.2. CONCRETE

Concrete in proximity causes a drop in efficiency, especially at high bands, but no shifting in frequency, so there is no need of a readjustment of the matching network as shown below. Generally, the shorter distance between the antenna and the concrete material, the lower the efficiency. It is seen that the antenna is robust towards detuning from the presence of concrete

and the performance is somewhat decreased, thus it is advised to keep some distance from concrete.

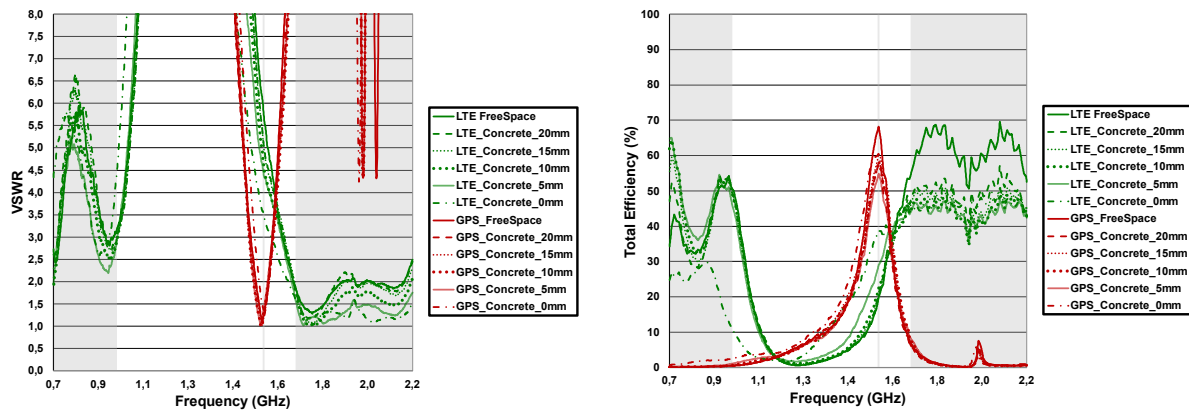

Figure 26 – VSWR & Total efficiency for the different bands covered by the L size board from Figure 10 and placed in close proximity to concrete.

	Concrete PCB (100 x 50)	698 – 748 MHz	746- 803 MHz	791- 849 MHz	824- 894 MHz	880-960 MHz	1710-2220 MHz	GPS 1575 MHz
Average Efficiency (%)	Free Space	40.4	34.0	33.5	39.3	50.5	62.1	67.5
	Distance 20mm	47.6	32.4	29.9	37.9	51.7	49.9	57.4
	Distance 15mm	54.4	36.3	31.0	37.1	50.6	46.7	59.6
	Distance 10mm	58.3	39.2	33.3	38.8	51.2	44.7	57.6
	Distance 5mm	58.7	41.5	37.3	42.7	50.9	44.1	54.2
	Distance 0mm	26.1	25.3	27.9	28.3	18.3	46.5	60.3

Table 5 - Total efficiency (%) in presence of concrete for LTE bands with TRIO mXTEND™ and GPS L1 band with DUO mXTEND™ at 5 distances between the PCB and the material.

5.3. BODY PHANTOM

Human/animal body in proximity has significant impact on the antenna performance, especially at the lowest band as seen below. Like for other materials, the further the antenna is from the material the higher the antenna performance. It is recommended to locate the placement with minimum exposure to the body and to leave as much distance as possible.

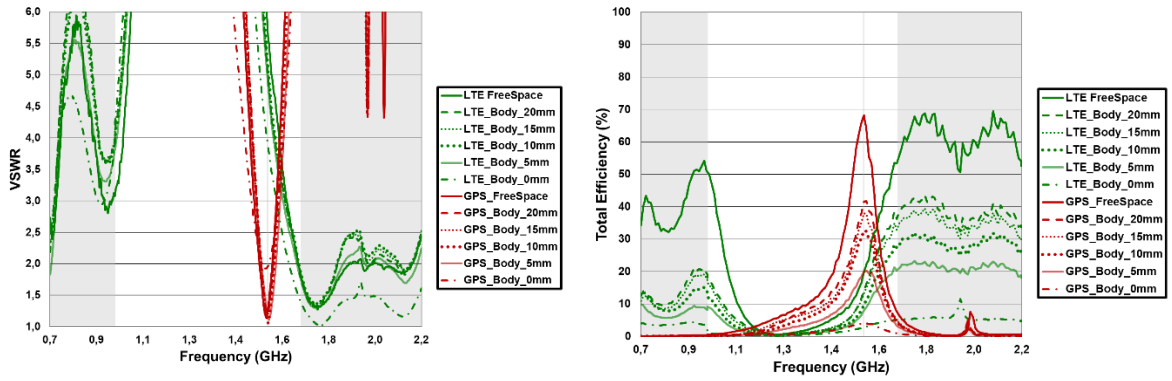

Figure 27 – VSWR & Total efficiency for the different bands covered by the L size board from Figure 10 and placed in close proximity to a body phantom.

	Body Phantom PCB (100 x 50)	698 – 748 MHz	746-803 MHz	791-849 MHz	824-894 MHz	880-960 MHz	1710-2220 MHz	GPS 1575 MHz
Average Efficiency (%)	Free Space	40.4	34.0	33.5	39.3	50.5	62.1	67.5
	Distance 20mm	12.7	9.9	10.8	14.4	19.9	38.6	40.6
	Distance 15mm	11.4	8.8	9.4	12.6	18.0	35.4	37.2
	Distance 10mm	12.2	8.5	8.1	10.1	14.0	29.1	32.0
	Distance 5mm	8.2	6.0	5.9	7.1	8.8	21.5	19.5
	Distance 0mm	3.7	3.4	3.6	4.0	4.0	5.7	4.0

Table 6 - Total efficiency (%) in presence of a body phantom for LTE bands with TRIO mXTEND™ and GPS L1 with DUO mXTEND™ at the 5 distances tested between PCB and the material.

5.4. METAL

Metal is probably the most challenging material when placed close to an antenna. As Figure 28 and Table 7 show, the impact in proximity on the antenna performance is significant. A reconfiguration/retuning of the matching network is required to adjust to the specific distance between the device and the metal.

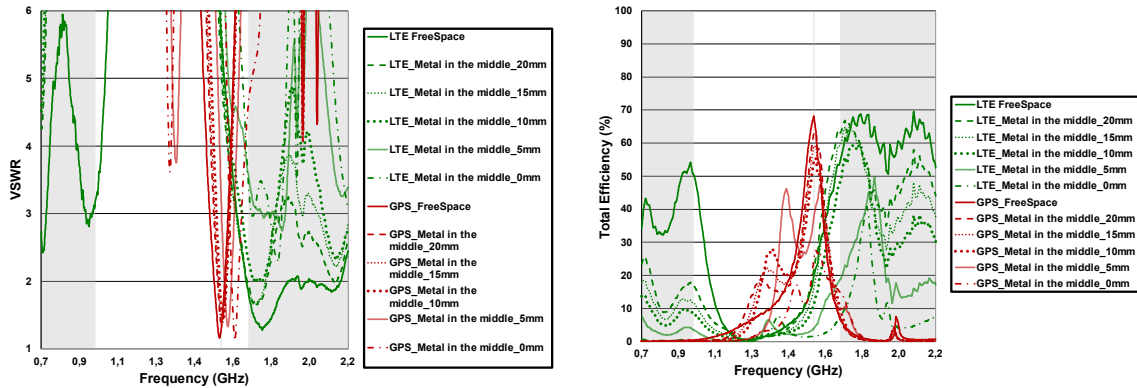

Figure 28 – VSWR & total efficiency for the different bands covered by the L size board from Figure 10 and placed in close proximity to metal.

	Metal PCB (100 x 50)	698 – 748 MHz	746-803 MHz	791-849 MHz	824-894 MHz	880-960 MHz	1710-2220 MHz	GPS 1575 MHz
Average Efficiency (%)	Free Space	40.4	34.0	33.5	39.3	50.5	62.1	67.5
	Distance 20mm	23.5	13.5	9.4	11.8	16.4	51.6	61.9
	Distance 15mm	16.7	10.0	7.1	9.1	12.3	45.7	58.1
	Distance 10mm	12.3	7.0	5.1	6.3	9.2	40.1	53.4
	Distance 5mm	5.3	2.9	2.1	2.5	3.9	24.7	36.2
	Distance 0mm	0.5	0.3	0.3	0.4	0.5	12.4	23.6

Table 7 - Total efficiency (%) in presence of a metal for LTE bands with TRIO mXTEND™ and GPS L1 with DUO mXTEND™ at 5 distances between PCB and the material.

6. SUMMARY OF DESIGN STEPS

This Design Guide has shown the detailed considerations and major influential factors on the antenna performance during a typical cellular IoT design journey. By using the Virtual Antenna® solution, antenna performance can be tuned and optimized at every step, reducing the risk of board redesigns which can create delays and budget overruns, as well as the risk of failing costly certification requirements.

The key steps to consider designing antenna integration in your next cellular IoT device are:

Step 0 – Start early

- Antenna should be taken into consideration once you have identified your RF module.

Step 1 – Assess antenna design feasibility

- Identify cellular frequency bands necessary with operator and corresponding certification requirements.
- Use Antenna Intelligence Cloud™ to simulate total efficiency and reflection coefficient.
- Consider antenna response influence by PCB size and materials in proximity. Adjust dimensions if needed.
- Consider active matching network with switch for small devices (50 x 50 mm or smaller) especially when you need to meet high certification requirements.
- Estimate Total Radiated Power (TRP) for certification feasibility.

Step 2 – Build antenna design Gerber file:

- Use Gerber templates available on: <https://ignion.io/landing/nordic-semiconductor/>.
- Leverage matching network topology and design recommendations from Antenna Intelligence Cloud™ report.

Step 3 – Perform full device EM simulation

- Use microwave tool (or Ignion service) to simulate your full device considering components that might influence the antenna performance such as batteries, casing...
- Fine tune matching network and optimize design if needed.

Step 4 – Sanity check of final Gerber design file before production

- Final check (Ignion service) ensuring that the antenna, matching network layout and other design recommendations on the final Gerber are following the design recommendations before manufacturing the PCBs.

Step 5 – Produce prototype and verify antenna performance

- Validate antenna is correctly tuned by measuring reflection coefficient with VNA (or use Ignion service).
- Verify optimal total efficiency with anechoic chamber measurements (Ignion service).
- Evaluate if performance is affected by proximity material, fine tune if needed.

Step 6 – Perform pre-certification tests of antenna

- Perform OTA test to validate meeting TRP/TIS requirements (Ignion service).
- Fine tune matching network, if needed.
- Submit to certification house.

6.1. OVERVIEW OF IGNION SUPPORT SERVICES

Virtual Antenna® makes antenna optimization accessible for any electronics engineer, however if in need of support during the product development, the Ignion team is ready to help every step of the design journey.

Figure 29 Ignion services for antenna integration.

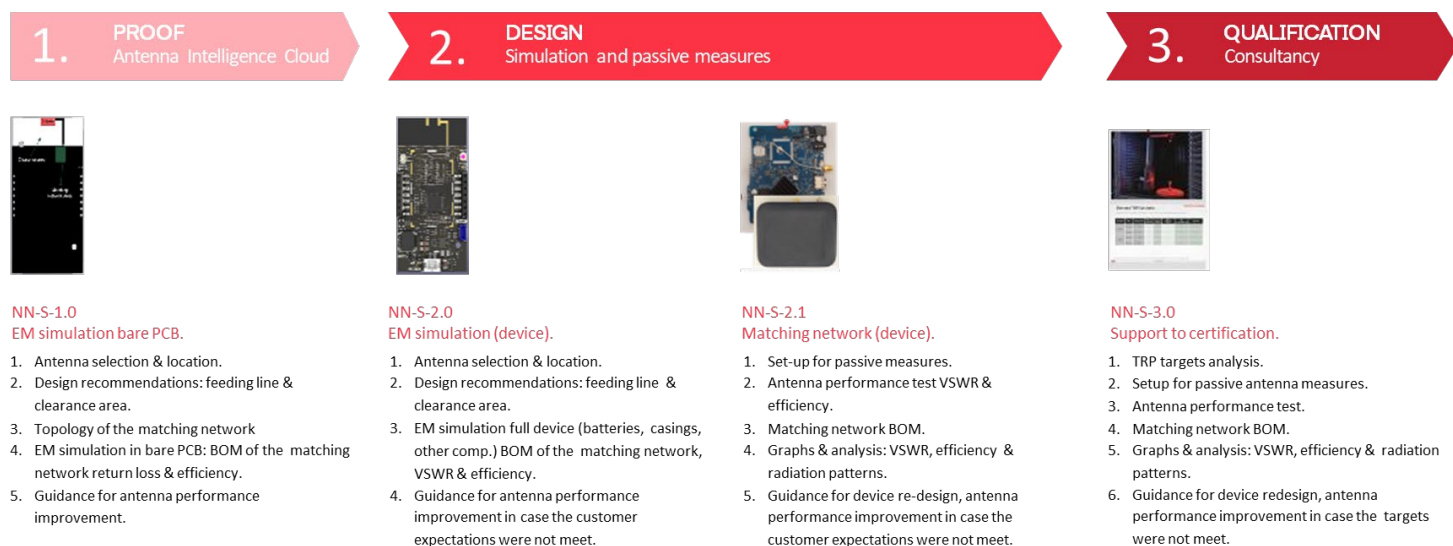

Please contact support@ignion.io for any questions related to the services. If designing a **different device size** or a **different frequency band** than presented in this guide, use the free-of-charge¹ [Antenna Intelligence Cloud™](https://ignion.io), which will deliver a complete design report including a custom matching network for your device in 24h¹. Additional information on Ignion's services is available at: <https://ignion.io/rdservices/>

¹ See terms and conditions for a free Antenna Intelligence Cloud™ service in 24h at: <https://ignion.io/landing/nordic-semiconductor/>

The TRIO mXTEND™ and the DUO mXTEND™ antenna components and other Ignion products based on its proprietary Virtual Antenna® technology are protected by one or more of the following [Ignion patents](#).

All information contained within this document is property of Ignion and is subject to change without prior notice. Information is provided “as is” and without warranties. It is prohibited to copy or reproduce this information without prior approval.

Ignion is an ISO 9001:2015 certified company. All our antennas are lead-free and RoHS and REACH compliant.

ISO 9001: 2015 Certified



ignion[™]

Your innovation.
Accelerated.

Contact:
support@ignion.io
+34 935 660 710

Barcelona

Av. Alcalde Barnils, 64-68 Modul C, 3a pl.
Sant Cugat del Vallés
08174 Barcelona
Spain

Shenzen

Topway Information Building, Binhai Avenue,
Nanshan District, N° 3369 – Room 2303
Shenzen, 518000
China

+86 13826538470

Tampa

8875 Hidden River Parkway
Suite 300
Tampa, FL 33637
USA