

Kinetic Technologies

PRODUCT GUIDE 2026 Q2

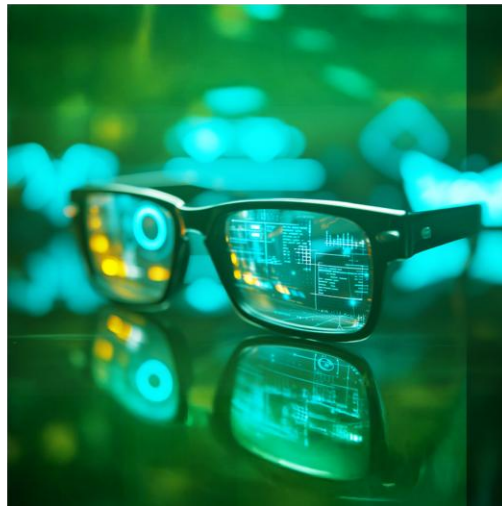
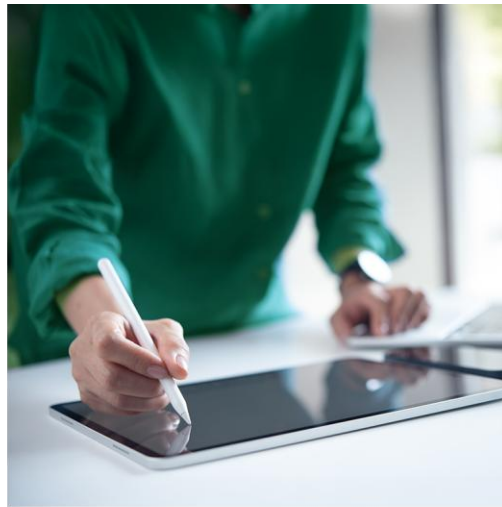

Innovation in motion™

Table of Contents

USB and USB-C Overvoltage and Surge Protection ICs	3
Single-channel Load Switches with OVP	3
Current Limited Load Switch with Reverse Blocking Protection	3
Single-Channel Load Switches with OVP and Surge Protection.....	3
Single Input, Dual Output Load Switches with OVP and Surge Protection.....	3
USB and USB-C Overvoltage and Surge Protection ICs (continued).....	5
Flat-Clamp TVS for Surge and ESD Protection	5
USB-PD Protected Switch.....	5
Current Sink	5
Current Source.....	5
Current Source or Current Sink	5
USB Data Line Protection ICs.....	7
Interface and Isolation ICs.....	7
Load Switches	7
Load Switch Controller.....	7
eFuses	7
General Purpose I/O Expanders.....	7
Smart Push Button Reset ICs	7
LCD Backlight and Bias Power ICs	9
Single-Channel Backlight LED Drivers	9
Multi-Channel Backlight LED Drivers	9
LCD Bias Power Supplies	9
Camera LED Flash Driver ICs.....	9
High Current LED Flash Drivers	9
RGB LED Driver ICs.....	11
Constant Current RGB LED Drivers	11
IR LED Drivers.....	11
Wireless Power Receiver ICs	11
Power Over Ethernet ICs.....	11
EMI/ESD Suppressor ICs.....	11
DC-DC Converter ICs	13
Buck.....	13
Dual Buck + Quad LDO	13
Boost	13
Buck & Boost.....	13
Isolated DC-DC Converter/Controller	13
Non-Isolated DC-DC Converter/Controller	13
Evaluation Kits.....	15

USB and USB-C Overvoltage and Surge Protection ICs

Single-channel Load Switches with OVP													
Device	VIN (V)	VIN MAX (V)	SURGE (V)	RON (mΩ)	IMAX (A)	RBP	RCP	OCP	CLP	OTG	OVP Adj	Package	Package Size (L x W)
KTS1640/1	6.0 - 40	-30 to 42		41	6.0	✓						TDFN-12	4.0 x 4.0mm
KTS1642Q/AQ ¹	4.0 - 40	-30 to 42		41	6.0	✓						TDFN-12	4.0 x 4.0mm
KTS1670	2.7 - 30	30		60	3.0					✓	✓	WLCSP-6 UDFN-8	1.0 x 1.2mm 2.0 x 2.0mm
KTS1671	2.7 - 28	30		60	3.0					✓	✓	WLCSP-6	1.0 x 1.2mm

Current Limited Load Switch with Reverse Blocking Protection													
Device	VIN (V)	VIN MAX (V)	SURGE (V)	RON (mΩ)	IMAX (A)	RBP	RCP	OCP	CLP	OTG	OVP Adj	Package	Package Size (L x W)
KTS1688	2.5 - 5.5	28 (V _{OUT})		68	2.5	✓			✓	✓		WLCSP-9	1.22 x 1.22mm
KTS1661	2.5 - 5.5	29 (V _{OUT})		53	2.5	✓	✓	✓	✓	✓		WLCSP-9	1.31 x 1.31mm
KTS1665 ²	2.5 - 5.5	29 (V _{OUT})		53	3.3	✓	✓	✓	✓	✓		WLCSP-9	1.31 x 1.31mm

Single-Channel Load Switches with OVP and Surge Protection													
Device	VIN (V)	VIN MAX (V)	SURGE (V)	RON (mΩ)	IMAX (A)	RBP	RCP	OCP	CLP	OTG	OVP Adj	Package	Package Size (L x W)
KTS1650B	2.3 - 28	29	±200	36	4.5					✓	✓	WLCSP-12	1.49 x 2.16mm
KTS1652	2.75 - 21.5	28	±200	9	6.0					✓		WLCSP-20	2.46 x 1.97mm
KTS1668	2.3 - 30	30	±100	38	4.0					✓	✓	WLCSP-12	1.29 x 1.99mm
KTS1675	3.0 - 28	28	±100	20	5.0	✓				✓		WLCSP-20	2.22 x 1.82mm
KTS1675A	3.0 - 28	28	±100	25	5.0	✓				✓		WLCSP-20	2.22 x 1.82mm
KTS1676	3.0 - 28	28	±100	20	5.0	✓				✓		WLCSP-20	2.22 x 1.82mm
KTS1680A/C/D/E	2.3 - 28	29	±100	28	4.5					✓	✓	WLCSP-12	1.21 x 1.7mm
KTS1681A	2.3 - 28	29	±100	28	4.0					✓	✓	WLCSP-12	1.21 x 1.7mm
KTS1682	2.3 - 28	29	±100	38	4.0					✓	✓	WLCSP-12	1.29 x 1.99mm
KTS1686	3.0 - 28	29	±100	65	4.5	✓				✓	✓	WLCSP-15	1.6 x 2.1mm
KTS1693 ²	2.7 - 28	30	±110	9	6.0			✓		✓	✓	WLCSP-20	2.13 x 1.905mm

Single Input, Dual Output Load Switches with OVP and Surge Protection													
Device	VIN (V)	VIN MAX (V)	SURGE (V)	RON (mΩ)	IMAX (A)	RBP	RCP	OCP	CLP	OTG	OVP Adj	Package	Package Size (L x W)
KTS1678B	2.7 - 13.5	-2 to 28	±100	23/30	3.5/6	✓				✓		WLCSP-28	1.67 x 2.96mm

Definitions													
OVP - Overvoltage protection	OCP - Overcurrent protection	CLP - Current Limit Protection	RBP - Reverse blocking protection	RCP - Reverse current protection	OTG - USB On-The-Go Operation								

1. AEC-Q100 Automotive qualified parts available. Please contact your local sales representative.

2. Safety approvals: UL 2367 and IEC 62368-1.

Automotive Single-channel Load Switch with OVP

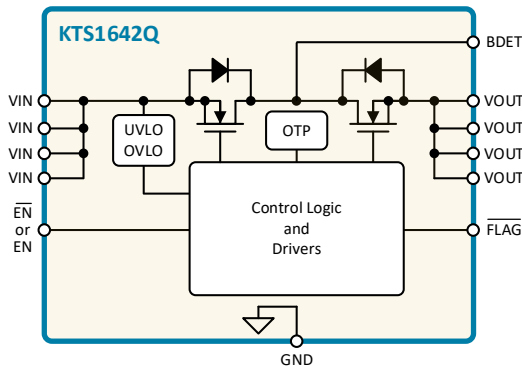

6.0A, Fixed OVP with -28V Reverse Input Voltage Protection and RBP

Current Limited Load Switch with Reverse Blocking Protection

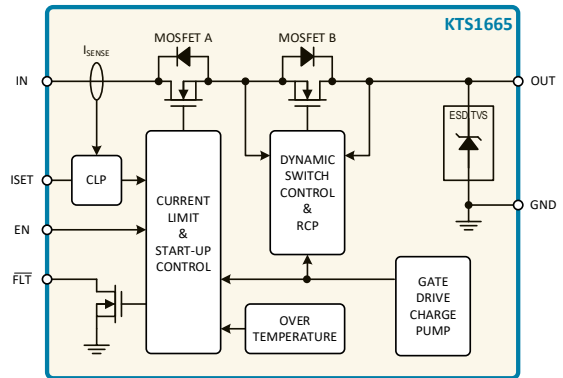

3.3A, 5V Adjustable Current Limit Load Switch with RBP, RCP and SCP on V_{OUT}

Single-Channel Load Switches with OVP and Surge Protection

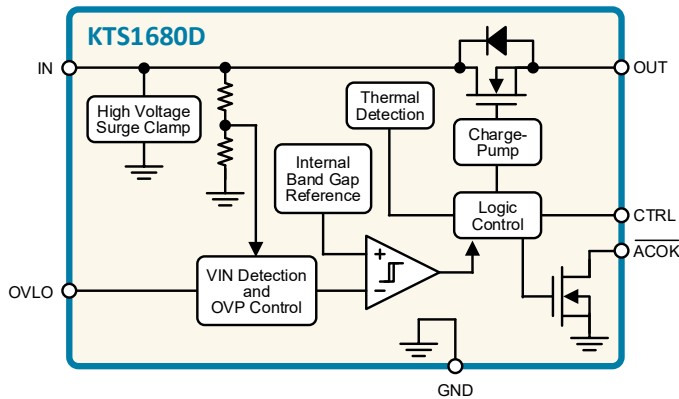

20V/4.5A, 13.9V Fixed or Adjustable OVP with ±100V Surge Protection

Single-Channel Load Switches with OVP and Surge Protection

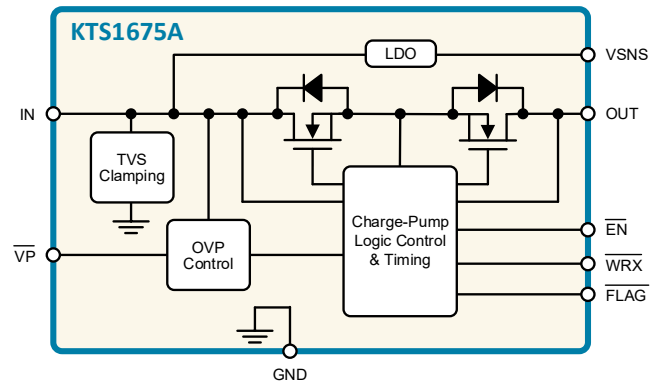

20V/5A, ±100V Surge, 13V/23.4V Fixed OVP with RBP & OTG

Single-Channel Load Switches with OVP and Surge Protection

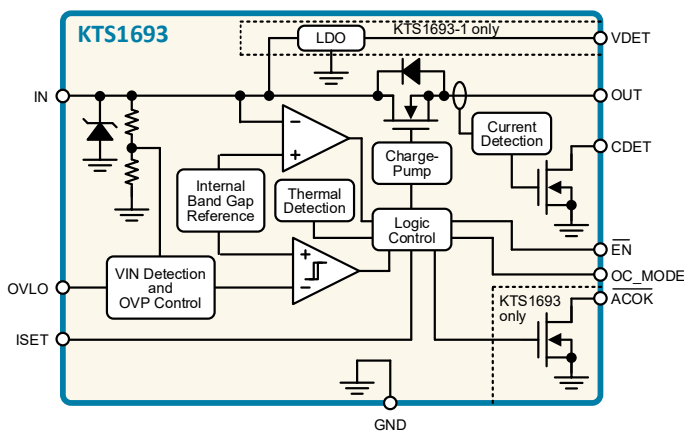

20V/6A, ±100V Surge, 5.95V Fixed or Adjustable OVP with adj. OCP

Single Input, Dual Output Load Switches with OVP and Surge Protection

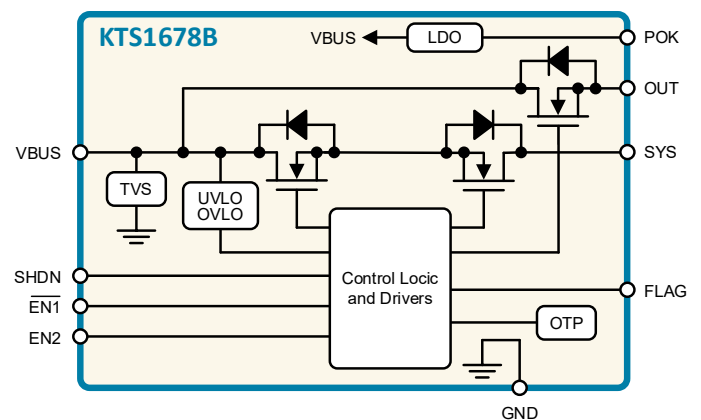

Single Input, Dual Output, 20V, 3.5A/6A, ±100V Surge, 13.9V/5.25V Fixed OVP with RBP

USB and USB-C Overvoltage and Surge Protection ICs (continued)

Flat-Clamp TVS for Surge and ESD Protection								
Device	V _{RWM} (V)	V _{BR MAX} (V)	SURGE (V)	I _{PP MAX} (8/20μs) (A)	V _{CL MAX} (8/20μs) (V)	P _{PP MAX} (8/20μs) (W)	Package	Package Size (L x W)
KTS1289	33	33.6	±200V	80	39	3300	WLCSP-6	1.66 x 1.56mm
KTS1287-25	25	25.5	±250V	110	30.5	3300	WLCSP-6	1.66 x 1.56mm
NEW KTS1287-28	28	28.5	±250V	110	33.5	3300	WLCSP-6	1.66 x 1.56mm

USB-PD Protected Switch													
Device	V _{IN} (V)	V _{IN MAX} (V)	SURGE (V)	RON (mΩ)	I _{MAX} (A)	RBP	RCP	OCP	CLP	OTG	OVP Adj	Package	Package Size (L x W)
Current Sink													
KTS1672	3.0 - 24	29	35	25	5.0	✓	✓	✓			✓	WLCSP-12	1.64 x 2.18mm
KTS1673A/B	3.0 - 24	29	35	22	5.0	✓	✓	✓			✓	WLCSP-12	1.64 x 2.18mm
KTS1677A	3.0 - 23	30	±90	30	5.0	✓		✓			✓	WLCSP-15	2.57 x 1.57mm
KTS1691A/B	3.0 - 24	29	35	14.5	7.0	✓	✓	✓			✓	WLCSP-15	2.86 x 1.68mm
KTS1697A	3.0 - 23	29	±90	11	7.0	✓	✓	✓			✓	WLCSP-25	2.7 x 2.7mm
KTS1655	3.0 - 24	29	35	14	7.0	✓	✓	✓			✓	WLCSP-20	2.49 x 2.23mm
KTS1698	3.0 - 23	29	±90	25	5.0	✓	✓	✓			✓	WLCSP-15	2.62 x 1.64mm
KTS1897	3.0 - 33	39	45	24	6.5	✓	✓	✓			✓	WLCSP-20	2.56 x 2.00mm
KTS1898	3.0 - 33	35	±100	24	6.5	✓	✓	✓			✓	WLCSP-25	2.56 x 2.56mm
Current Source													
KTS1690A ³	2.5 - 5.5	29 (V _{OUT})	±80	30	3.3	✓	✓	✓	✓	✓		WLCSP-16	1.98 x 1.98mm
KTS1890 ³	2.5 - 5.5	35 (V _{OUT})	±130	27	4.0	✓	✓	✓	✓	✓		WLCSP-20	2.49 x 1.99mm
Current Source or Current Sink													
KTS1673C/D	3.0 - 24	29	35	22	5.0			✓		✓	✓	WLCSP-12	1.64 x 2.18mm
KTS1691C/D	3.0 - 24	29	35	14.5	7.0			✓		✓	✓	WLCSP53-15	2.86 x 1.68mm
KTS1800	3.0 - 55	59	±180	25	7.0	✓	✓	✓	✓	✓	✓	WLCSP-63	4.81 x 3.79mm
NEW KTS1801	3.0 - 55	56	±130	31	6.0	✓	✓	✓		✓	✓	WLCSP-42	3.09 x 3.86mm
KTS1865 ³	3.0 - 23	29	±100	20	6.5	✓	✓	✓	✓	✓	✓	WLCSP-20	2.71 x 2.16mm

Definitions					
OVP - Overvoltage protection	OCP - Overcurrent protection	CLP - Current Limit Protection	RBP - Reverse blocking protection	RCP - Reverse current protection	OTG - USB On-The-Go Operation

3. Safety approvals: UL 2367 and IEC 62368-1.

Flat-Clamp TVS for Surge and ESD Protection

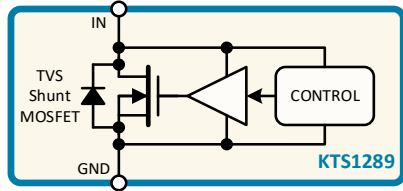

±200V Surge Protection Active Flat-Clamp TVS for EPR 28V System

USB-PD Protected Switch – Current Sink

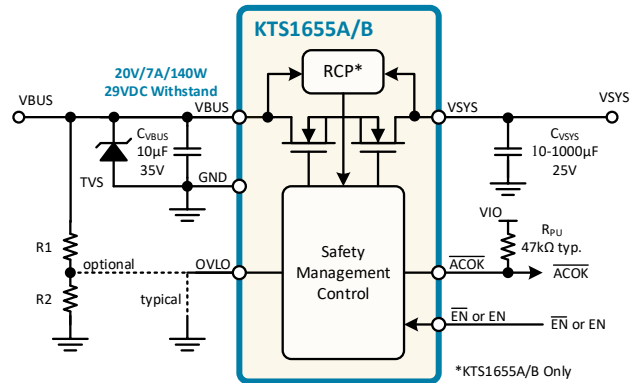

20V/7A/140W, 24V Fixed or Adjustable OVP with RBP, RCP and SCP

USB-PD Protected Switch – Current Source

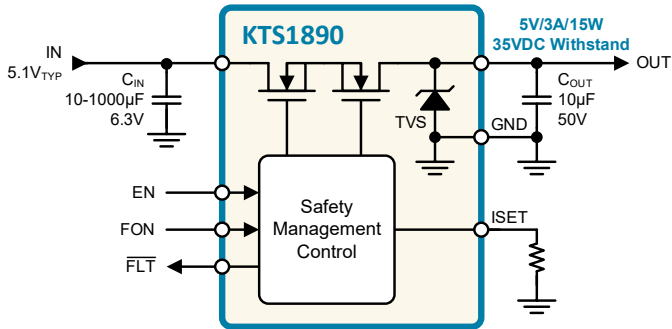

4.0A, ±130V Surge, 5V Adjustable Current Limit Load Switch with RBP, RCP and SCP on V_{OUT}

USB-PD Protected Switch – Current Sink

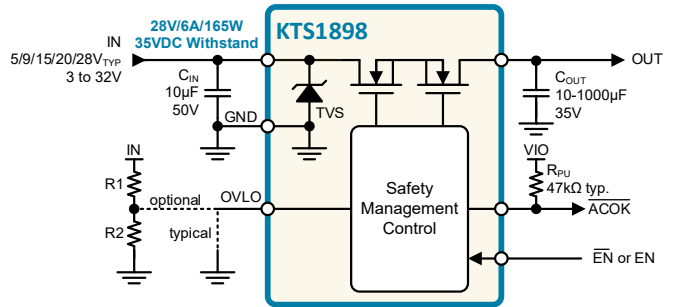

6.5A, ±100V Surge, 35V OVP Switch with RBP, RCP and SCP

USB-PD 48V EPR Protected Switch – Current Source/Sink

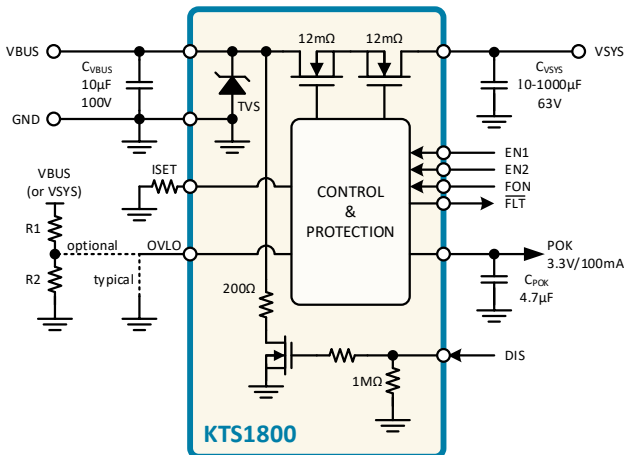

48V/7A, ±180V Surge, Bi-Directional Load Switch with OVP, OCP, RBP, RCP, CL, SCP and POK Safe LDO

USB-PD Protected Switch – Current Source/Sink

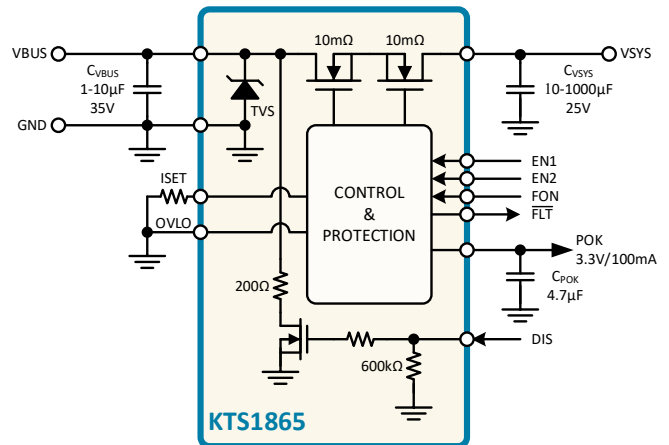

20V/6.5A, ±100V Surge, Bi-Directional Load Switch with OVP, OCP, RBP, RCP, CL, SCP and POK Safe LDO

USB Data Line Protection ICs

Device	VIN (V)	Protects			Protection			Switches		Package	Package Size (L x W)
		D+/D-	CC1/2	SBU1/2	OVP	Surge	ESD	RON	Cap		
KTU1001A	2.7 - 5.5	✓ ⁴		✓ ⁴	+24V in 100ns	+25V		6Ω	4.0pF	WLCSP-12	1.17 x 1.57mm
KTU1101	2.5 - 5.5		✓	✓	+24V in < 15ns	CC1/2 = ±80V SBU1/2 = ±35V	Air: ±15kV Contact: ±8kV	CC = 0.3Ω SBU = 4Ω	CC = 370pF SBU = 27pF	WLCSP-20	1.7 x 2.1mm
KTU1108	2.5 - 5.5		✓		+24V in < 15ns	CC1/2 = ±80V	Air: ±15kV Contact: ±8kV	0.24Ω	370pF	WLCSP-12	1.29 x 1.69mm
KTU1120	2.5 - 5.5		✓	✓ OVP=3.83V	+24V in < 15ns	CC1/2 = ±40V SBU1/2 = ±30V	Air: ±15kV Contact: ±8kV	CC = 0.27Ω SBU = 3Ω	CC = 40pF SBU = 11pF	WLCSP-16	1.7 x 1.7mm
KTU1121A ⁵	2.5 - 5.5		✓	✓ OVP=4.8V	+24V in < 70ns	CC1/2 = ±40V SBU1/2 = ±30V	Air: ±15kV Contact: ±8kV	CC = 0.27Ω SBU = 3Ω	CC = 40pF SBU = 11pF	WLCSP-16 TQFN-20	1.7 x 1.7mm 3.0 x 3.0mm
KTU1128 ⁵	2.5 - 5.5		✓	✓ OVP=4.8V	+32V in < 30ns	CC1/2 = ±60V SBU1/2 = ±40V	Air: ±25kV Contact: ±10kV	CC = 0.27Ω SBU = 3Ω	CC = 33pF SBU = 11pF	WLCSP-16 WQFN-20	1.694 x 1.694mm 3.0 x 3.0mm
KTU1131 ⁵	2.5 - 5.5	✓	✓	✓	+22V in < 15ns		Air: ±10kV Contact: ±5kV	CC = 0.27Ω SBU = 3Ω	CC = 15pF SBU = 6pF	UQFN-20	3.0 x 3.0mm
KTU1133 ⁵	2.7 - 4.5		✓	✓	+63V in < 60ns	CC1/2 = ±90V SBU1/2 = ±90V	Air: ±15kV Contact: ±8kV	CC = 300mΩ SBU = 4.5Ω	CC = 50pF SBU = 9pF	WQFN-20	3.0 x 3.0mm

Interface and Isolation ICs

Load Switches							
Device	VIN (V)	RON (mΩ)	IMAX (A)	OVP	RBP	Package	Package Size (L x W)
KTS1601	1.5 - 5.5	24.0 @3.3VIN	2.0		✓	WLCSP-4	1.0 x 1.0mm
KTS1605	1.5 - 5.5	13.4 @3.3VIN	5.0		✓	WLCSP-6	1.0 x 1.5mm
KTS1640/1	6.0 - 40	41	6.0	✓	✓	TDFN-12	4.0 x 4.0mm
KTS1642Q/AQ ⁶	4.0 - 40	41	6.0	✓	✓	TDFN-12	4.0 x 4.0mm

Load Switch Controller						
Device	VIN (V)	Reverse Voltage Rating	Gate Peak Sink Current (A)	Regulated Source to Drain Voltage (mV)	Package	Package Size (L x W)
KTS1900 (Q ⁶)	4.0 - 60	-65V	1.5	40	SOT23-6	2.9 x 1.6mm

eFuses								
Device	VIN (V)	RON (mΩ)	Min I _{LIM} (A)	Max I _{LIM} (A)	Soft Start	Fault Response	Package	Package Size (L x W)
KTS1630A	4.5 - 18	31	1	5.1	Adjustable	Auto-Retry	VDFN-10	3.0 x 3.0mm
KTS1630B	4.5 - 18	31	1	5.1	Adjustable	Latched-off	VDFN-10	3.0 x 3.0mm

General Purpose I/O Expanders							
Device	VIN (V)	Max. Driver Current per Channel (mA)	# of I/Os	Interrupt Out	Addresses	Package	Package Size (L x W)
KTS1620	1.65 - 5.5	25	24	✓	4	FO-WLP66-36 TQFN55-32L	2.6 x 2.6mm 5.0 x 5.0mm
KTS1622	1.65 - 5.5	25	16	✓	4	FO-WLP55-25 TQFN44-24L	2.0 x 2.0mm 4.0 x 4.0mm

Smart Push Button Reset ICs

Part Number	VIN (V)	Quiescent Current (μA)	Ship Mode Current (μA)	Reset Request Time (s)	Discharge Paths	Discharge Time (ms)	Discharge Current (mA)	Package	Package Size
KTS1612	2.2 - 5.5	<1	<1	10	2	400	52	UQFN2.0x1.5-10	2.0 x 1.5mm
KTS1613	1.6 - 5.5	<1	<1	10		400		UQFN2.0x1.5-10	2.0 x 1.5mm

4. KTU1001A can protect D+/D- or SBU1/2.

5. Thunderbolt™ Compatible.

6. AEC-Q100 Automotive qualified parts available. Please contact your local sales representative.

USB Type-C Port Protector

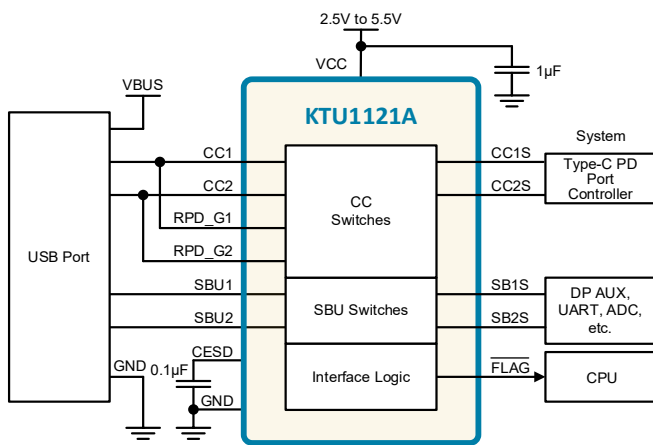

USB Type-C Port Protector (Thunderbolt™ compatible option) for CC and SBU Pins

USB Type-C Port Protector

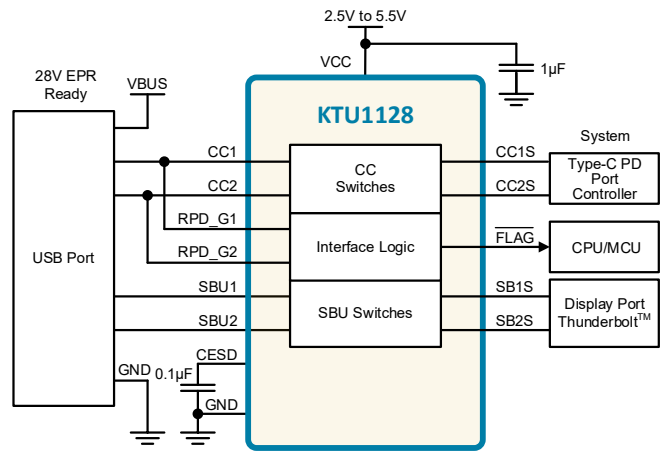

USB Type-C 28V EPR Port Protector (Thunderbolt™ compatible) for CC and SBU Pins

USB Type-C Port Protector

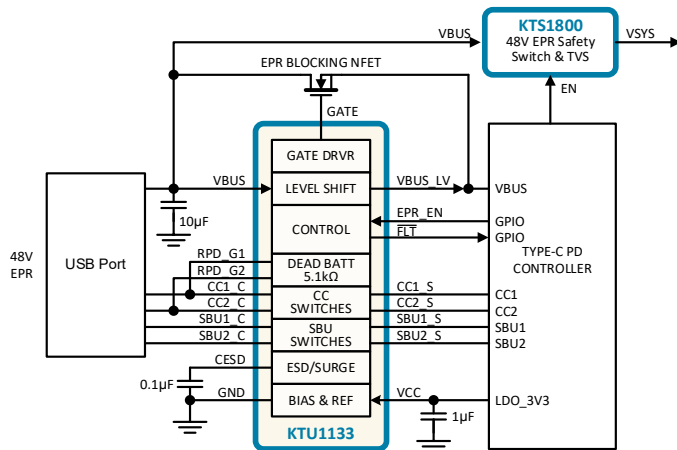

USB Type-C Port Protector for CC and SBU Pins

Load Switch IC

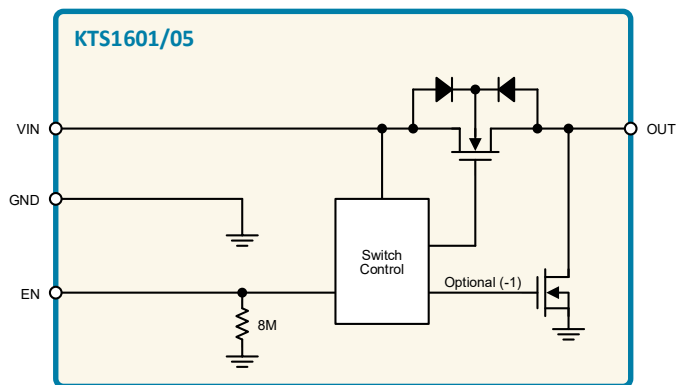

2A/5A Slew Rate Controlled Load Switch with RBP

General Purpose I/O Expander IC

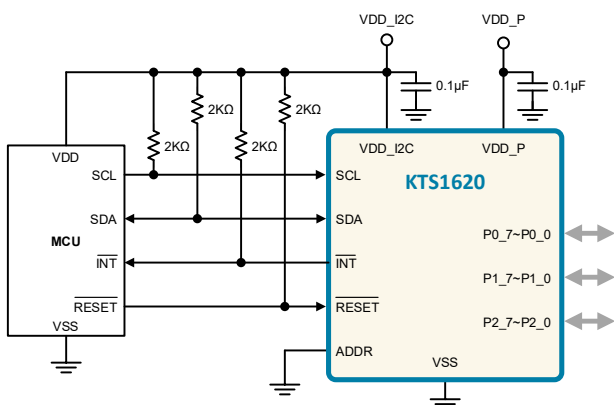

Low Voltage 24-bit I²C I/O Expander

Dual-Input Smart Push Button Reset IC

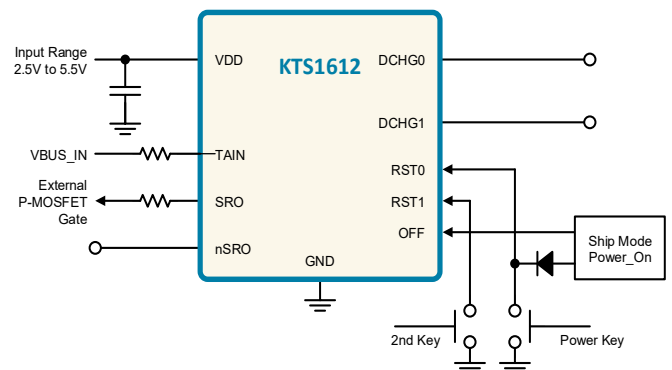

Dual-Input Push Button Reset IC with Two Discharge Paths

LCD Backlight and Bias Power ICs

Single-Channel Backlight LED Drivers										
Device	VIN (V)	# LED Channels	LEDs/CH	Total LEDs	Switch Current (A)	I ² C	Single Wire	PWM	OVP (V)	Package
KTD2801B	2.7 - 5.5	1	6	6	0.52		✓	✓	24	TDFN22-6
KTD2801A	2.7 - 5.5	1	8	8	0.52		✓	✓	30	TSOT23-6/TDFN22-6
KTD2801	2.7 - 5.5	1	10	10	0.52		✓	✓	36	TSOT23-6/TDFN22-6
KTD2500	2.7 - 5.5	1	10	10	0.75		✓	✓	38	TDFN22-6
KTD2505R	2.7 - 5.5	1	10	10	1.2		✓	✓	38	TDFN22-6
KTZ8850 ⁷	3.0 - 5.5	1	10	10	1.3	✓		✓	Adj < 36	WLCSP-18

Multi-Channel Backlight LED Drivers										
Device	VIN (V)	# LED Channels	LEDs/CH	Total LEDs	Switch Current (A)	I ² C	Single Wire	PWM	OVP (V)	Package
KTD3133	2.7 - 5.5	2	8	16	1.8	✓		✓	25.9/32	WLCSP-12
KTD3134	2.7 - 5.5	2	8	16	2.6	✓		✓	25.9/32	WLCSP-12
KTD3136	2.7 - 5.5	3	8	24	2.6	✓		✓	25.9/32	WLCSP-12
KTD3137	2.7 - 5.5	3	8	24	2.6	✓		✓	25.9/32	WLCSP-12
KTD3156B	2.7 - 5.5	6	10	60	2.5			✓	Adj < 40	TQFN33-16
KTZ8863A ⁷	2.9 - 5.5	3	8	24	2.1	✓		✓	Adj < 32	WLCSP-24
KTZ8864A ⁷	2.7 - 5.5	4	8	32	2.1	✓		✓	Adj < 32	WLCSP-24
KTZ8866 ⁷	2.7 - 5.5	6	10	60	2.5	✓		✓	Adj < 40	WLCSP-28
KTZ8868 ⁷	2.7 - 5.5	8	10	80	2.5	✓		✓	Adj < 40	WQFN55-32
KTZ8869 ⁷	2.7 - 5.5	8	10	80	2.5	✓		✓	Adj < 40	WQFN55-32

LCD Bias Power Supplies							
Device	VIN (V)	I ² C	Max. Current per Output (mA)	VOUT (V)	Accuracy (%)	IQ Shutdown (SDA=SCL=1.8V) (µA)	Package
KTD2151	2.7 - 5.5	✓	80	4.0~5.2V, -4.0~-5.2V, 100mV Steps	1.5	6	WLCSP-15
KTZ8850 ⁷	3.0 - 5.5	✓	80	4.0~6.3V, -4.0~-6.3V, 12.5mV Steps	2.0	1	WLCSP-18
KTZ8863A ⁷	2.9 - 5.5	✓	150	4.0~6.3V, -4.0~-6.3V, 50mV Steps	1.5	1	WLCSP-24
KTZ8864A ⁷	2.7 - 5.5	✓	150	4.0~6.3V, -4.0~-6.3V, 50mV Steps	1.5	1	WLCSP-24
KTZ8866 ⁷	2.7 - 5.5	✓	200	4.0~6.3V, -4.0~-6.3V, 50mV Steps	1.5	1	WLCSP-28
KTZ8868 ⁷	2.7 - 5.5	✓	250	4.0~6.3V, -4.0~-6.3V, 50mV Steps	1.5	1	WQFN55-32
KTZ8869 ⁷	2.7 - 5.5	✓	300	4.0~6.3V, -4.0~-6.3V, 50mV Steps	1.5	1	WQFN55-32

Camera LED Flash Driver ICs

High Current LED Flash Drivers							
Device	VIN (V)	# LED Channels	IMAX (A)	I ² C	Type	Package	Package Size (L x W)
KTD2681	2.7 - 5.5	1	1.5	✓	BOOST	WLCSP-12	1.3 x 1.57mm
KTD2688A	2.7 - 5.5	2	1.5/1.5	✓	BOOST	WLCSP-12	1.3 x 1.57mm
KTD2686	2.7 - 5.5	3	1.5/1.0/0.5	✓	BOOST	WLCSP-12	1.42 x 1.66mm
KTD2690	2.7 - 5.5	1	1.5	✓	BOOST	WLCSP-8/ UDFN-10 ⁸	1.519 x 0.808mm / 2mm x 2mm
KTD2691	2.7 - 5.5	1	1.5	✓	LINEAR	WLCSP-8	0.808 x 1.519mm

7. Integrated LED Driver IC and LCD Bias IC.

8. Please contact Kinetic Technologies Sales for availability.

Single-Channel LED Backlight Driver IC with LCD Bias

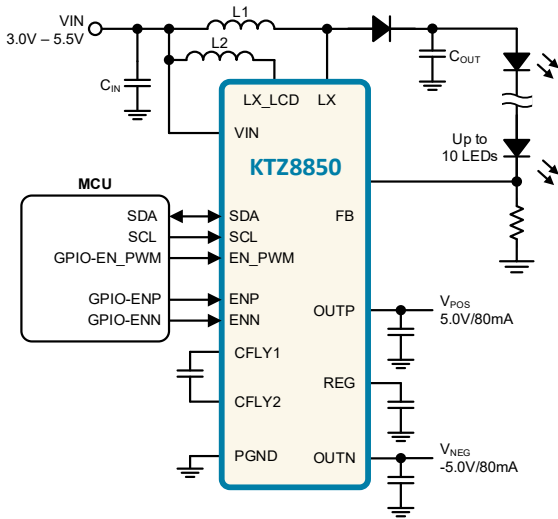

Complete LCD Backlight and Bias Power

Multi-Channel LED Backlight Driver IC

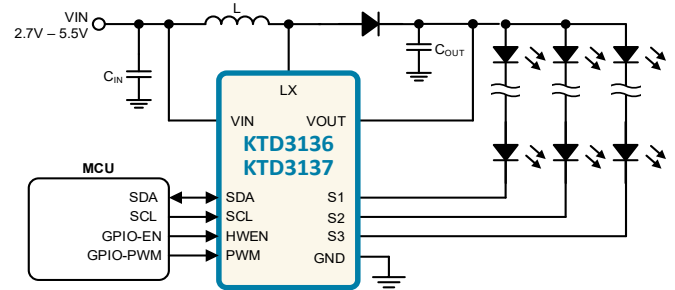

3-Channel, 2.6A/32V Integrated Switch (KTD3136) with Panel Flash (KTD3137)

Multi-Channel LED Backlight Driver IC with LCD Bias

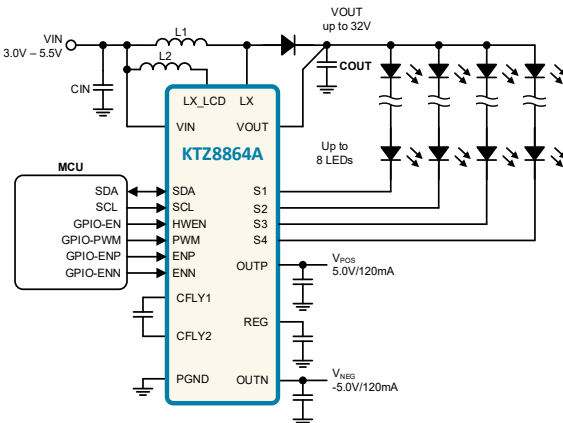

4-Channel, Complete LCD Backlight and Bias Power

Multi-Channel LED Backlight Driver IC with LCD Bias

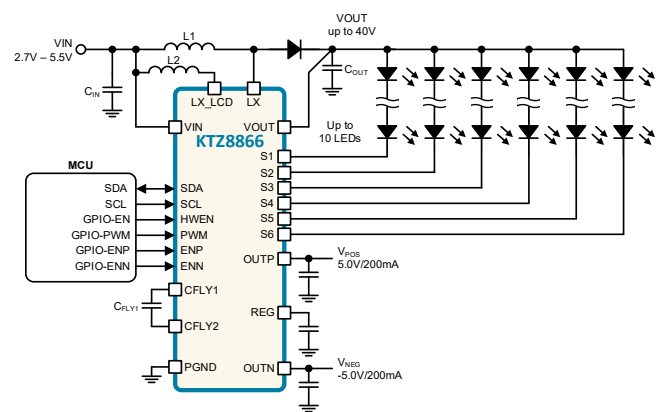

6-Channel, Complete LCD Backlight and Bias Power

Multi-Channel LED Backlight Driver IC with LCD Bias

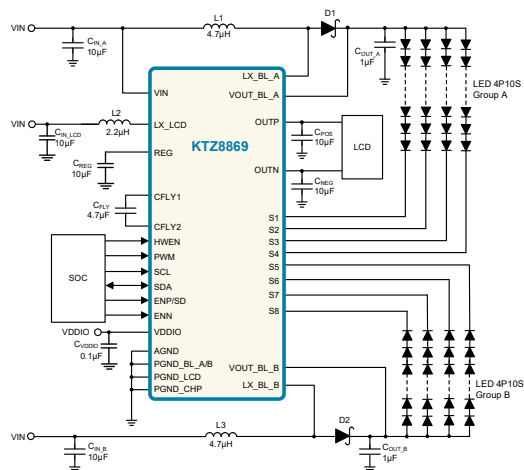

8-Channel, Complete LCD Backlight and Bias Power

Flash LED Driver IC

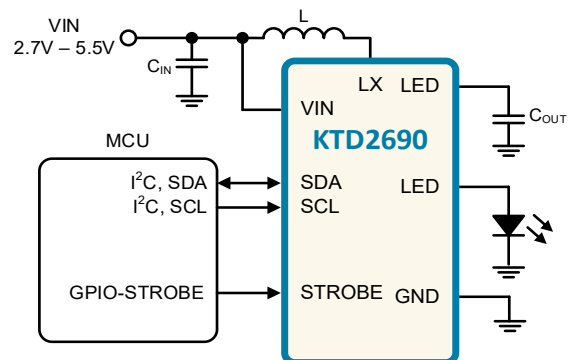

1-Channel, 1.5A Flash/Torch/IR Mode LED Driver

RGB LED Driver ICs

Constant Current RGB LED Drivers								
Device	VIN (V)	# LED Channels	IMAX (mA)	Levels	Interface	AECQ100 Approved	Package	Package Size (L x W)
KTD2026	2.7 - 5.5	3	24	192	I ² C		UTDFN-8	1.5 x 1.5mm
KTD2027	2.7 - 5.5	4	24	192	I ² C		UTDFN-8	1.5 x 1.5mm
KTD2037	2.7 - 5.5	3	24	191	I ² C		UTDFN-8	1.5 x 1.5mm
KTD2042	2.7 - 5.5	9	24	64	I ² C		UQFN-20	3.0 x 3.0mm
KTD2052A/C ⁹	2.5 - 5.5	12	24	192	I ² C		UDFN-8	2.0 x 2.0mm
KTD2052B/D/F ⁹	2.5 - 5.5	12	24	192	I ² C		UDFN-8	2.0 x 2.0mm
KTD2058 (Q ¹⁰) ¹¹	2.5 - 5.5	36	24	192	I ² C	✓	UQFN-20	3.0 x 3.0mm
KTD2059 (Q ¹⁰) ¹¹	2.5 - 5.5	36	24	192	I ² C	✓	UQFN-20	3.0 x 3.0mm
KTD2060 (Q ¹⁰) ¹¹	2.5 - 5.5	36	24	192	I ² C	✓	UQFN-20	3.0 x 3.0mm
KTD2061 (Q ¹⁰)	2.5 - 5.5	36	24	192	I ² C	✓	UQFN-20	3.0 x 3.0mm
KTD2064A	2.5 - 5.5	24	24	192	I ² C		UQFN-20	3.0 x 3.0mm
KTD2064B ¹²	2.5 - 5.5	24	24	192	I ² C		UQFN-20	3.0 x 3.0mm

IR LED Drivers								
KTD2041	2.7 - 5.5	9	32	64	I ² C		UQFN-20	3.0 x 3.0mm

Wireless Power Receiver ICs

Device	Function	Wireless Power Standard	Recommended Operating Range (V)	Output Voltage (V)	Output Power Max (W)	Maximum Output Current (A)	Package	Package Size (L x W)
KTE7000	Power Receiver	WPC/Qi 1.3 BPP	4.0 - 18	5.0	5	1.5	WLCSP-52	2.66 x 3.90mm
KTE7001	Power Receiver	WPC/Qi 1.3 EPP	4.0 - 18	5.0 in BPP Mode 9/12 in EPP Mode	15	1.5	WLCSP-52	2.66 x 3.90mm
KTE7200	Power Receiver	WPC/Qi 1.3 BPP	3.6 - 10	5.1	5	1	TQFN-24	5 x 5mm

Power Over Ethernet ICs

Device	VIN (V)	Power (W)	802.3af/at/bt Power Level				Key Description	Power Supply Configuration				Package
			Type 1	Type 2	Type 3	Type 4		Flyback	Forward	PSR	Buck	
KTA1136	37 - 57	13	✓				PD+DC/DC Converter and FET	✓		✓	✓	QFN44-16
KTA1137A	9.5 - 57	30	✓	✓			PD and DC/DC	✓		✓	✓	QFN55-20
KTB1095	5 - 80	70	✓	✓	✓	✓	Synchronous Flyback ¹³	✓				SOP-16
KTA1140	9.5 - 57	71	✓	✓	✓	✓	PD only	✓	✓	✓	✓	WQFN55-20
KTA1142	37 - 57	72	✓	✓	✓	✓	PD+DC/DC Controller	✓	✓	✓	✓	WQFN44-32
KTA1170	2.7 - 75	71	✓	✓	✓	✓	Dual MOSFET Bridge Rectifier	✓	✓	✓	✓	WDFN44-8
KTB2140	8 - 80	200	✓	✓	✓	✓	DC/DC	✓	✓	✓	✓	WQFN33-16

EMI/ESD Suppressor ICs

Device	VIN (V)	# of Channels	CISPR22 and FCC Part 15	IEC 61000-4-2 ESD (Air Discharge)	IEC 61000-4-2 ESD (Contact Discharge)	Cable Discharge Event (CDE)	Package
KTA1550	2.17 - 3.47	2	Class B, for Radiated and Conducted Emissions	±25kV	±25kV	±25kV	QSOP-16L
KTA1552	2.17 - 3.47	4					DFN94-36L

9. KTD2052A/C = defaults disabled at initial power-up; KTD2052B/D/F = execute AutoBreathe™ pattern by default at initial power-up or at reset

10. AEC-Q100 Automotive qualified parts available. Please contact your local sales representative.

11. Alternate I²C Address to KTD2061.

12. Alternate I²C Address to KTD2064A.

13. With integrated feedback and digital isolator.

Constant Current RGB LED Driver IC

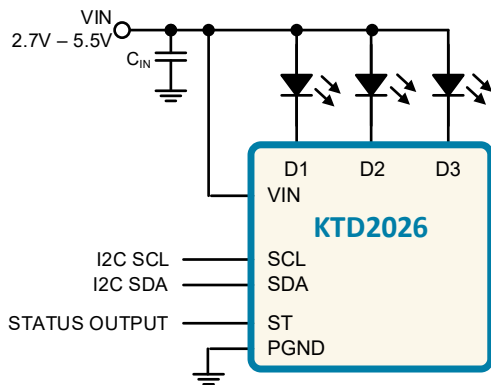

3-Channel RGB LED Driver with I²C Dimming

Constant Current RGB LED Driver IC

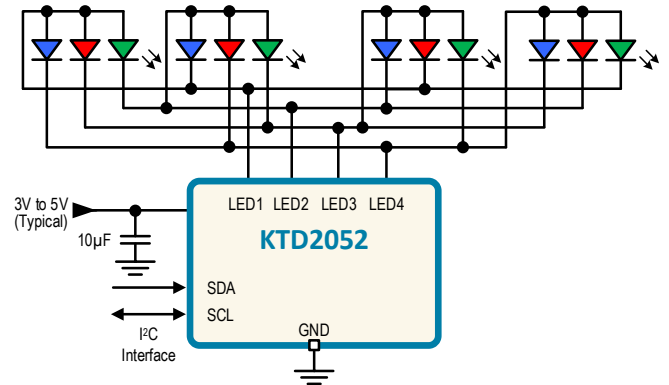

12-Channel RGB LED Driver with I²C Control

Constant Current RGB LED Driver IC

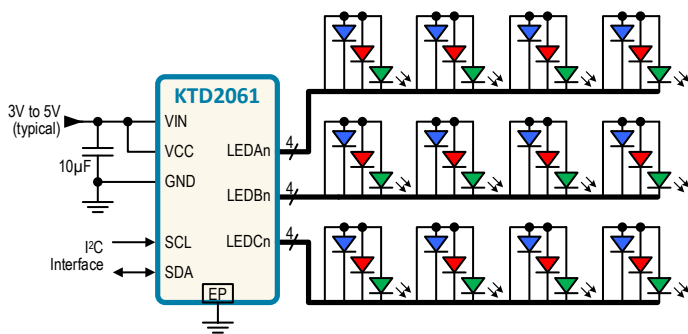

36-Channel RGB LED Driver with I²C Control

Wireless Power Receiver

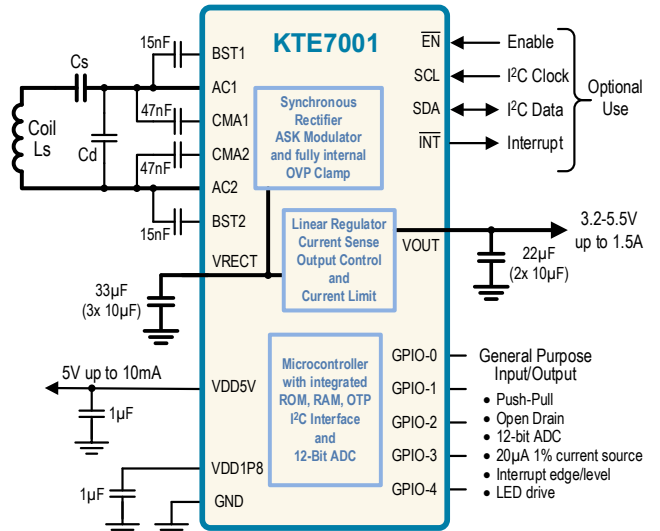

15W Wireless Power Receiver for WPC/Qi BPP/EPP

PoE PD and DC-DC Controller

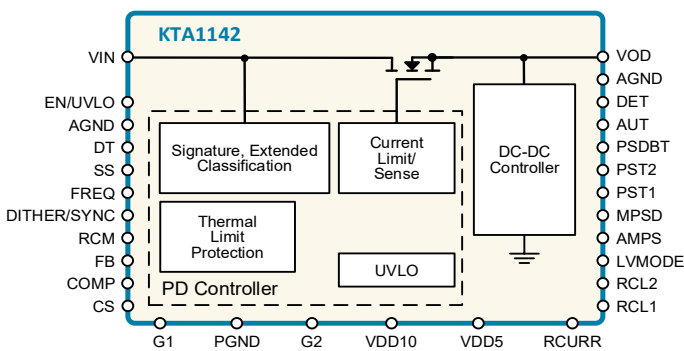

72W/90W (802.3bt-Compliant) PoE PD and DC-DC Controller

EMI/ESD Suppression IC

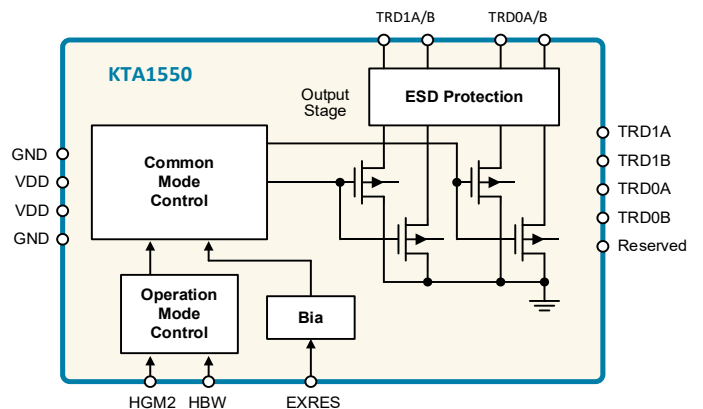

Dual Channel Active EMI & ESD Suppressor

DC-DC Converter ICs

Buck										
Device	VIN (V)	VOU (V)	FSW (MHz)	IMAX Current (mA)	IQ (µA)	Interface	Output Auto-Discharge	OptiComp™	Package	Package Size (L x W)
NEW KTB8311-BT ¹⁴	2.5 - 5.5	0.5 - 3.3	2	2500	39	EN/MODE (V _{out} /FPWM/Auto-skip)	Yes		PwrCSP™ HP-WLCSP-6	1.464mm x 1.064mm
KTB8316-AA ¹⁴	2.5 - 5.5	0.3 - 1.65	1	2500	39	EN/MODE (V _{out} /FPWM/Auto-skip)	Yes		PwrCSP™ HP-WLCSP-6	1.464mm x 1.064mm
KTB8316-BD ¹⁴	2.5 - 5.5	0.6 - 1.8	2	2500	39	EN/MODE (V _{out} /FPWM/Auto-skip)	Yes		PwrCSP™ HP-WLCSP-6	1.464mm x 1.064mm
KTB8316-CJ	2.5 - 5.5	1.0 - 3.3	4	2500	39	EN/MODE (V _{out} /FPWM/Auto-skip)	Yes		PwrCSP™ HP-WLCSP-6	1.464mm x 1.064mm
KTB8331	2.5 - 5.5	0.6 - 3.345	2.4	3000	48	I ² C/EN	Yes		WLCSP-15	1.31mm x 2.015mm
KTB8399	2.5 - 5.5	0.6 - 3.345	2.4	3000	46	I ² C/EN	Yes		WLCSP-15	1.34mm x 2.045mm
KTB8370A	4.7 - 17	5.0	0.5	5000	50	EN/PG	Yes		WLCSP-20	1.7mm x 2.0mm
KTB8370B	4.7 - 17	3.3	0.5	5000	50	EN/PG	Yes		WLCSP-20	1.7mm x 2.0mm
KTB8370C	4.7 - 17	1.8	0.5	5000	50	EN/PG	Yes		WLCSP-20	1.7mm x 2.0mm
KTB8371	4.7 - 17	0.8 - 5.5	0.5	5000	50	I ² C	Yes		WLCSP-20	1.7mm x 2.0mm
KTB8372C	4.7 - 18	1.8	0.5	5000	50	EN/PG	Yes		FCQFN-11	2.5mm x 2.2mm
KTB8375	4.5 - 24	0.55 - 6.0	<2.0	6000	45	I ² C/EN	Yes		FCQFN-12	2.5mm x 3.0mm
KTB8400	2.5 - 5.5	0.6 - 3.345	2.4	3000	46	I ² C/EN	Yes	✓	WLCSP-15	1.34mm x 2.045mm

Dual Buck + Quad LDO								
Device	VIN (V)	VOU (V)	IMAX Current (mA)	IQ (µA)	Interface	Output Auto-Discharge	Package	Package Size (L x W)
KTZ8701	2.7 - 5.5	Bucks: 0.6 - 3.3, 12mV Steps LDOs: 1.2 - 3.5, 25mV Steps	Bucks: 1200 LDOs: 300	140	I ² C	Yes	WLCSP-25	2.42mm x 2.35mm

Boost							
Device	VIN (V)	VOU (V)	IMAX Current (mA)	IQ (µA)	Interface	Package	Package Size (L x W)
KTC2110	2.5 - 5.5	5	1000	60	EN/PT	WLCSP-9	1.38mm x 1.38mm
KTC2110A	2.5 - 5.5	5.4	1000	60	EN	WLCSP-9	1.38mm x 1.38mm
KTC2115	2.5 - 5.5	5	1500	56	EN/PT	WLCSP-9	1.27mm x 1.30mm

Buck & Boost								
Device	VIN (V)	VOU (V)	IMAX Current (mA)	IQ (µA)	Interface	Output Auto-Discharge	Package	Package Size (L x W)
KTZ8812	2.7 - 5.5	+4.0 to +5.2, 100mV Steps -4.0 to -5.2, 100mV Steps	150	620	I ² C/ENP/ENN	Yes	WLCSP-15 TDFN3x2.5-14	2.2mm x 1.45mm 3.0mm x 2.5mm

Isolated DC-DC Converter/Controller									
Device	VIN (V)	VOU (V)	Output Power (W)	IQ (mA)	Integrated Isolated Feedback	Isolation Voltage	DC-DC Topology	Package	Package Size (L x W)
KTB1095 ¹⁵	5 - 80	3.3 - 24	70	5	✓	3kV	Synchronous Flyback	SOP-16	10.3mm x 7.5mm
KTB1100 ¹⁵	7 - 80	3.3 - 48	15	2.5	✓	3kV	Flyback with FET	SOP-16	10.3mm x 7.5mm
KTB2140	8 - 80	3.3 - 48	200	1	-	external	Flyback or Forward, Active Clamp	WQFN-16	3mm x 3mm

Non-Isolated DC-DC Converter/Controller								
Device	VIN (V)	VOU (V)	Output Power (W)	IQ (mA)	Interface	DC-DC Topology	Package	Package Size (L x W)
KTC3500	3.5 - 60	3.3 - 48	100	0.5	EN	Boost, Flyback, SEPIC	DFN33-10	3mm x 3mm

Buck Converter

Boost Converter

14. Please contact Kinetic Technologies Sales for availability.

15. Safety approval: UL1577.

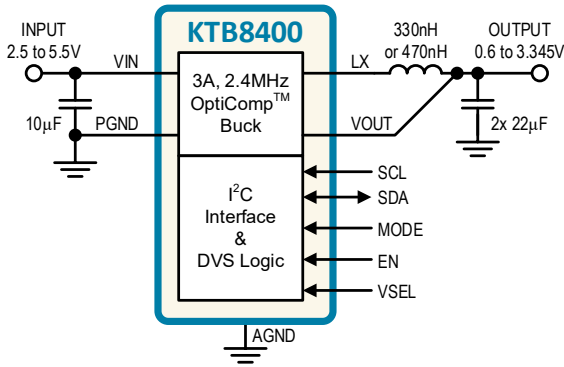

3A Synchronous AOT Buck with OptiComp™

Buck Converter

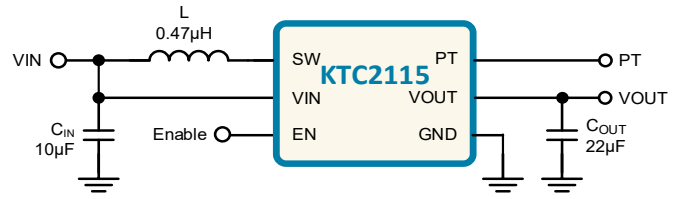

1.5A, Low Iq, Synchronous Boost

Isolated Flyback Converter

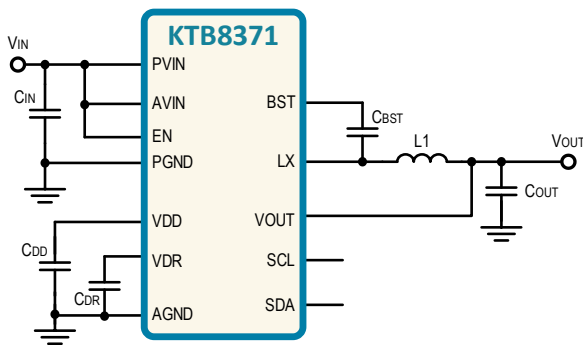

4.7V to 17V Input, 5A Synchronous Buck Regulator with I²C Interface

Isolated Flyback Converter

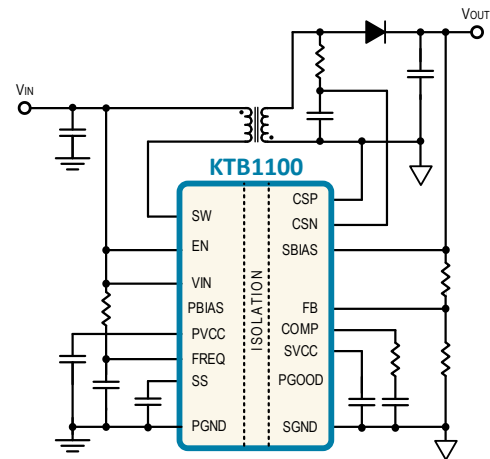

Isolated Flyback Regulator with Integrated Feedback and Digital Isolator

Isolated Flyback or Forward Converter

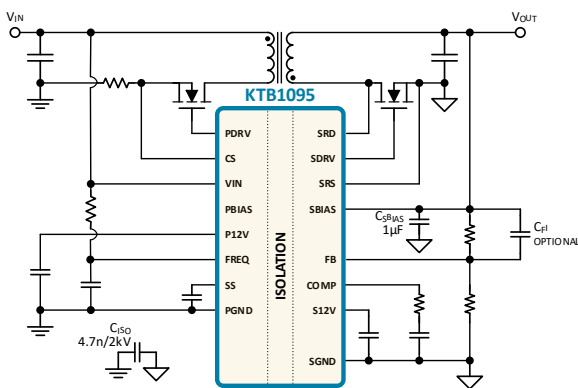

Isolated Flyback Regulator with Integrated Feedback and Digital Isolator

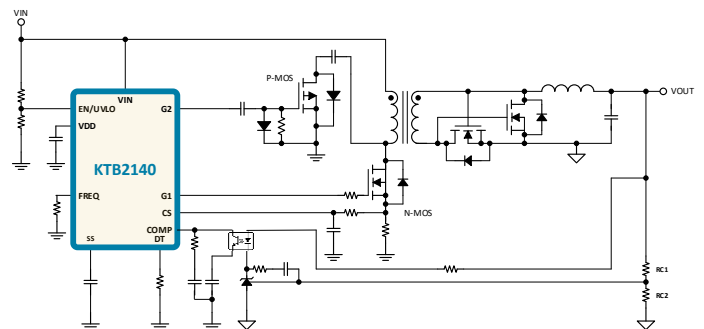

Active Clamp Current-Mode PWM Controller

Evaluation Kits

Part Number	Evaluation Kit Number	Description
KTA1137A	KTA1137AEUAB-MMEV02	IEEE 802.3at PoE PD with Integrated DC-DC Controller
KTA1140 + KTB1095 + KTA1170	KTA1140EUAQ-WA-MCEV01	IEEE 802.3af/at/bt PoE PD and Flyback Controller (includes: <i>KTB1095</i> and <i>KTA1170</i>)
KTA1140 + KTB2140 + KTA1170	KTA1140EUAQ-WB-MCEV01	IEEE 802.3af/at/bt PoE PD and Flyback Controller (includes: <i>KTB2140</i> and <i>KTA1170</i>)
KTA1142 forward + KTA1170 + KTS1900	KTA1142EUAT-ZU-MCEV02 ¹⁶	IEEE 802.3bt-Compliant, PoE Powered Device with DC-DC Controller (Evaluating forward topology)
KTA1142 flyback + KTA1170 + KTS1900	KTA1142EUAT-ZT-MCEV02 ¹⁶	IEEE 802.3bt-Compliant, PoE Powered Device with DC-DC Controller (Evaluating flyback topology)
KTA1170	KTA1170GVAE-MMEV01	Integrated Dual MOSFET Bridge Rectifier for Power over Ethernet
KTB1095	KTB1095EYAA-MMEV01	Synchronous Flyback Controller with Integrated Feedback & Digital Isolator
KTB1100	KTB1100EYAA-MMEV01	15W Flyback Regulator with Digital Isolator Integrated Feedback
KTB2140	KTB2140GUAP-MMEV01	Active Clamp Forward Current-Mode PWM Controller
KTB8316	KTB8316EEAA-CJ-ZZ-MMEV01	4MHz, High Accuracy 2.5A Low-Voltage AOT Synchronous Buck Regulator
KTB8331	KTB8331DEDA-MMEV02	3A, 2.4MHZ, Low-Voltage, I ² C Programmable Buck Regulator
KTB8400	KTB8400AEDAA-MMEV01	Low Voltage Buck with Accurate F _{sw} and Fast Transient Response
KTC2110	KTC2110ECAA-MMEV02	3.0MHz High Efficiency Low I _Q Boost Regulator
KTC3500	KTC3500EVAC-MMEV01	3.5V to 60V Input Boost/SEPIC/Flyback DC-DC Controller
KTD2026	KTD2026EWE-MMEV01	Constant Current RGB LED Driver with I ² C Control
KTD2027	KTD2027EWE-MMEV01	Constant Current RGB/White LED Driver with I ² C Control
KTD2052	KTD2052AEVAA-MMEV01	12-Channel RGB LED Drivers with I ² C Control
KTD2061	KTD2061EUAC-MMEV02	36-Channel RGB LED Drivers with I ² C Control
KTD2690	KTD2690ERAA-MMEV01	Single Flash LED Driver with Programmable 1.5A Current Source
NEW KTS1289	KTS1289ECAE-MMEV01	Flat-Clamp Mini TVS for High Voltage Surge & ESD Protection
KTS1601	KTS1601EUM-1-MMEV01	2.0A Slew Rate Controlled Load Switch with Reverse Blocking
KTS1622	KTS1622EUAA-MMEV01	Low Voltage 16-Bit I ² C-bus I/O Expander
KTS1630	KTS1630AEVAD-MMEV01	5A eFuse with Current Limit Control and Reverse Blocking FET Control
KTS1640	KTS1640EDV-MMEV01	Load Switch with OVP and Reverse Polarity Protection
KTS1665	KTS1665ECAC-MMEV01	USB VBUS 3.3A Ideal Diode Load Switch with Current Limit
KTS1677A	KTS1677AEVH-MMEV01	5A _{RMS} VBUS Current-Sink Protection Load Switch
KTS1688	KTS1688EUH-MMEV01	Low Resistance Load Switch with Current Limit Control & Over-Voltage Reverse Blocking Protection
KTS1690A	KTS1690AEGAA-MMEV01	USB VBUS I _{SOURCE} Load Switch with Current Limit Control
KTS1693	KTS1693EVB-MMEV01	Surge Protected Load Switch with OVP and OCP
KTS1697A	KTS1697AEOAB-MMEV01	7A _{RMS} VBUS Current-Sink Protection Load Switch
KTS1698	KTS1698AEDAB-MMEV01	5A _{RMS} VBUS Current-Sink Protection Load Switch
NEW KTS1897 + KTS1289	KTS1897BEIAD-MMEV01	6A _{RMS} VBUS OVP Load Switch for 28V EPR Systems
KTS1898A	KTS1898AEOAE-MMEV01	6A _{RMS} VBUS I _{SINK} Load Switch for 28V EPR Systems
KTS1900Q Ideal Diode	KTS1900QGXA-ZS-MMEV01	KTS1900Q EVAL Kit - Ideal Diode Controller with Reverse Input Protection
KTS1900Q Load Switch	KTS1900QGXA-ZR-MMEV01	KTS1900Q EVAL Kit - Load Switch Controller with Reverse Input Protection
KTU1108	KTU1108EFAA-MMEV01	USB Type-C Protector for CC Pins
KTU1128	KTU1128EUAJ-MMEV01	USB Type-C 28V EPR Port Protector for CC and SBU Pins
KTU1121A	KTU1121AEUAJ-MMEV01	USB Type-C Protector for CC and SBU Pins
KTU1133	KTU1133EUAJ-MMEV01	KTU1133 EVAL Kit - USB 48V EPR Port Protector for CC & SBU

16. Please contact Kinetic Technologies Sales for availability.



Kinetic Technologies

6399 San Ignacio Ave, Suite 250
San Jose, CA 95119, USA
Tel: +1 (408) 746-9000
www.kinet-ic.com